



U.S. Department of
Transportation
**Pipeline and
Hazardous Materials
Safety Administration**

East Building, PHH-23
1200 New Jersey Ave, SE
Washington, D.C. 20590

July 28, 2021

Dr. James M. Shuler
Manager, Packaging Certification Program
Department of Energy
U.S. Department of Energy
1000 Independence Ave, SW
EM-60
Washington, DC, 20585
USA

Dear Dr. James M. Shuler,

As your July 27, 2021 letter requested, Department of Energy has been registered as a user of IAEA Certificate of Competent Authority USA/0348/B(U)-85 for the MDS Nordion (Canada) Inc. Model F-231 and F-231-L, Serial Numbers 7, 8, and 9. This certificate, which revalidates the Canadian Certificate of Competent Authority No.2047 authorizes the transport of the package from the point of entry to final destination in the United States, from point of origin in the United States to point of exit, and through the United States.

A copy of the certificate is enclosed. All future revisions of the certificate will be forwarded to Department of Energy at James.Shuler@em.doe.gov.

Sincerely,

A handwritten signature in blue ink, appearing to read "Richard W. Boyle".

Richard W. Boyle, Chief
Radioactive Materials Branch
Office of Engineering and Research



U.S. Department
of Transportation

Pipeline and
Hazardous Materials
Safety Administration

East Building, PHH-23
1200 New Jersey Ave, SE
Washington, D.C. 20590

**COMPETENT AUTHORITY CERTIFICATION FOR A
TYPE B(U)
RADIOACTIVE MATERIALS PACKAGE DESIGN
CERTIFICATE USA/0348/B(U) , REVISION 16**

**REVALIDATION OF CANADIAN COMPETENT AUTHORITY
CERTIFICATE CDN/2047/B(U)**

The Competent Authority of the United States certifies that the radioactive material package design described in this certificate satisfies the regulatory requirements for a Type B(U) package as prescribed in the regulations of the International Atomic Energy Agency¹ and the United States of America² The package design is approved for use within the United States for import and export shipments made in accordance with applicable international and domestic transport regulations.

1. Package Identification - MDS Nordion (Canada) Inc. Model F-231 and F-231-L, Serial Numbers 7, 8, and 9.
2. Package Description and Authorized Radioactive Contents - as described in Canadian Certificate of Competent Authority CDN/2047/B(U), Revision 17 (attached).
3. General Conditions -
 - a. Each user of this certificate must have in his possession a copy of this certificate and all documents necessary to properly prepare the package for transportation. The user shall prepare the package for shipment in accordance with the documentation and applicable regulations.
 - b. Each user of this certificate, other than the original petitioner, shall register his identity in writing to the Office of Engineering and Research, (PHH-23), Pipeline and Hazardous Materials Safety Administration, U.S. Department of Transportation, Washington D.C. 20590-0001.

¹ "Regulations for the Safe Transport of Radioactive Material, 2012 Edition, No. SSR-6" published by the International Atomic Energy Agency (IAEA), Vienna, Austria.

² Title 49, Code of Federal Regulations, Parts 100-199, United States of America.

CERTIFICATE USA/0348/B(U) , REVISION 16

- c. This certificate does not relieve any consignor or carrier from compliance with any requirement of the Government of any country through or into which the package is to be transported.
 - d. Records of Management System activities required by Paragraph 306 of the IAEA regulations¹ shall be maintained and made available to the authorized officials for at least three years after the last shipment authorized by this certificate. Consignors in the United States exporting shipments under this certificate shall satisfy the applicable requirements of Subpart H of 10 CFR 71.
4. Special Conditions - This package is approved as meeting the requirements of the 1973 Edition of the IAEA regulations. Fabrication of new packagings is not authorized. The package design has not been evaluated against the requirements of the 2018 Edition of the IAEA regulations.
 5. Marking and Labeling - The package shall bear the marking USA/0348/B(U) in addition to other required markings and labeling.
 6. Expiration Date - This certificate expires on April 30, 2024. Previous editions which have not reached their expiration date may continue to be used.

This certificate is issued in accordance with paragraph(s) 820 of the IAEA Regulations and Section 173.473 of Title 49 of the Code of Federal Regulations, in response to the January 4, 2021 petition by Nordion (Canada) Inc., Ottawa, Ontario, and in consideration of other information on file in this Office.

Certified By:



William Schoonover
Associate Administrator for Hazardous
Materials Safety

March 22, 2021
(DATE)

Revision 16 - Issued to revalidate Canadian Certificate of Competent Authority No. CDN/2047/B(U), Revision 17 and to correct errors in Revision 15.



Certificate

CDN/2047/B(U) (Rev. 17)

Transport Package Design

The transport package design identified below is certified by the Canadian Nuclear Safety Commission pursuant to paragraph 21(1)(h) of the *Nuclear Safety and Control Act* and Subsection 10(1) of the *Packaging and Transport of Nuclear Substances Regulations, 2015* and to the 1973 Revised Edition (as amended) of the IAEA's *Regulations for the Safe Transport of Radioactive Material*.

REGISTRATION OF USE OF PACKAGES

All users of this authorization shall register their identity in writing with the Canadian Nuclear Safety Commission prior to the first use of this authorization and shall certify that they possess the instructions necessary for preparation of the package for shipment.

PACKAGE IDENTIFICATION

Designer: **Nordion (Canada) Inc.**
Make/Model: **F-231 and F-231-L, Serial Numbers 7, 8 and 9**
Mode of Transport: **Air, Sea, Road, Rail**

IDENTIFICATION MARK

The package shall bear the competent authority identification mark "**CDN/2047/B(U)**".

PACKAGE DESCRIPTION

The Model F-231 and F-231-L transport packagings as shown on MDS Nordion Drawing No. F 102001-001 (Issue AS) consist of a lead filled, steel encased cylindrical assembly with external fins, surrounded on the sides by an insulated cylindrical fire shield, on the top by a flame shield cap and heat screen, and on the bottom by a removable skid. There are vent and drain lines to facilitate loading, which are plugged by safety cables and capped. The cylindrical fire shield consists of 25 mm of "Kaowool" insulation sandwiched in steel and is attached to the packaging assembly by four hex head bolts. The heat screen covers the top flame shield cap and is attached to the cylindrical fire shield. The flame shield cap is fabricated of steel and is attached to the assembly via four slotted bracket assemblies and hex head steel bolts. The containment system consists of the capsule assemblies and the source cavity of the package.

For the F-231-L model transport package, stainless steel lift rings are added to raise the plug by 15.9 mm (0.63") or 34.9 mm (1.38"), thus increasing the height of the cavity.



An illustration of the transport packages is shown on attached Drawing No. F502001-002 (Issue A).

Any modification to the package design must be submitted to the CNSC for approval prior to implementation.

The configuration of the package is as follows:

Shape:	Cylinder	Shielding:	Lead
Mass:	7855 kg	Outer Casing:	Steel
Length:	n/a	Height:	1600 mm
Width:	n/a	Diameter:	1320 mm

AUTHORIZED RADIOACTIVE CONTENTS

The F-231 and F-231-L transport packages are authorized to contain a maximum of 9.25 PBq (255,000 Ci) of cobalt-60 metal contained within one of the following:

- either AC-195 Type capsules and bundles with 2, 3, or 4 capsules per bundle or AC-339 Type capsules and bundles with up to 6 capsules per bundle carried within a Model F-259 or F-350 eighteen-bundle carrier; or
- a maximum of 86 AC-345 Type capsules carried within a Model F-348 capsule carrier; or
- welded stainless steel capsules that meet the requirements of the ISO 2919:2012 standard of the International Organization for Standardization, under the Classification Number E53434 with the capsules retained within a holder that distributes them throughout the cavity volume.

For shipment of Cobalt 60 by air, the content is limited to 1.2 PBq.

MANAGEMENT SYSTEM

The management system for the design, manufacture, testing, documentation, use, maintenance and inspection of the package shall be in accordance with:

- Packaging and Transport of Nuclear Substances Regulations, 2015

SHIPMENT

The preparation for shipment of the package shall be in accordance with:

- MDS Nordion Procedure No. IN/PP 1482 F-231 (Rev. 6) "Preparation for Shipment of the F-231, F-231 (1996) and F-231-MK2 Type B(U) Transport Package (Dry Loading)"
- Packaging and Transport of Nuclear Substances Regulations, 2015

The average surface heat flux of the package with 14.8 PBq of Cobalt 60 is 970 W/m². For heat fluxes exceeding 15 W/m², supplementary arrangements must be made with the carrier to ensure adequate heat dissipation.



This certificate does not relieve the consignor from compliance with any requirement of the government of any country through or into which the package will be transported.

A handwritten signature in black ink, appearing to read 'R. Garg', is positioned above a horizontal line.

R. Garg
Designated Officer pursuant to paragraph 37(2)(a)
of the Nuclear Safety and Control Act

NOTES

Revision 15: March 17, 2015. Certificate renewed.

Revision 16: April 30, 2019. Certificate renewed. Shipment procedures updated.
Removed MDS Nordion Procedure IN/PP 1483 F-231.

Revision 17: December 9, 2020. Certificate amended to add the F-231-L configuration
and amend the authorized radioactive contents.

Parts list

1. Shield cap with vent holes
2. Retaining brackets for fireshield (4):
1 in. - 8 x 2 in. lg. hex. hd. bolt, washer, nut
3. Retaining brackets for shield cap (4):
3/8 - 16 x 1 1/2 in. lg. hex. hd. bolt, washer, nut
4. Plug screws: 3/4 x 1 3/4 in. lg. socket hd. (8)
and 7/8 - 9 x 2 1/2 in. lg. hex. hd. (2)
5. Heat screen mounting lugs
6. Radiation caution plate (2)
7. Nordion identification plate (2)
8. Removable fireshield
9. 3/4 - 10 x 2 in. lg. hex hd. bolts (4)
10. 3/8 in. NPT pipe plug and safety cable (2)
11. Wire seal installed through heads of hex head bolts (item 4)
12. Neoprene gasket
13. Vermiculite
14. Vent tube
15. Removable plug
16. Cavity 292 mm dia. x 445 mm (11.5 in. dia. x 17.5 in.)
17. Safety cables
18. Cap & nipple on end of drain line
19. Removable shipping skid
20. Drain tube
21. Warning plate (see note 9)
22. Warning - Storage plate: Nordion Dwg. A14649 (2)
23. Transite (steel encased) insulation
24. Heat screen
25. Crack shield ring
26. Lifting/tie-down lugs (4)
27. Shoulder type eyebolts (2) - zinc plated
28. Bolt (1) 3/4 - 10 x 2 in. lg. -zinc plated washers (2)
29. Bolt (4) 3/8 - 16 x 1 1/2 in. lg. hex. hd. - washers (8) lock washers (8) zinc plated
30. Category labels (2) on two opposite sides
31. UN number labels (2): one next to each of the two radioactive category labels
32. Upper Lift Ring for F-231-L configuration only
33. Gap Filler Ring for F-231-L configuration only

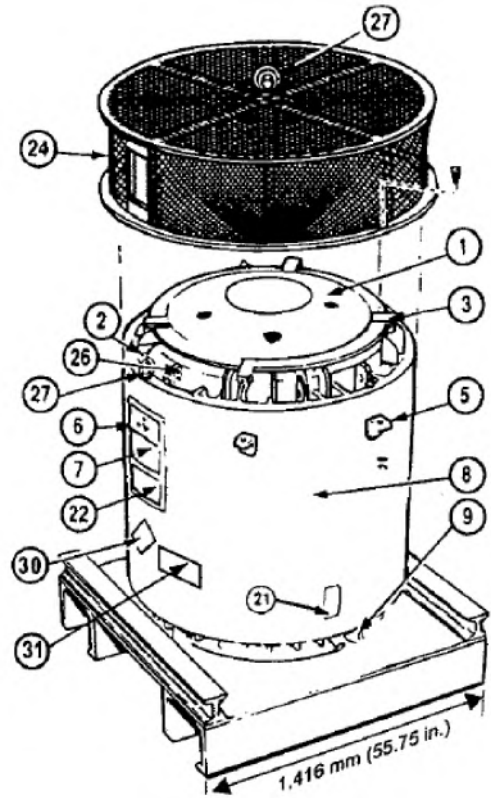

Notes

1. CNSC Certificate CDN/2047/B(U)
2. Meets IAEA Type B(U) requirements applicable to serial nos. 7, 8 and 9
3. Shielding 285 mm (11.25 in.) lead-steel encased
4. Gross weight: 7,858 kg max. (17,324 lb. max.)
5. Plug weight: 477 kg nominal (1,050 lb. nominal)
6. Floor loading (based on projected floor area):
3,919 kg/m² (803 lb./sq. ft.)
7. Maximum contents: 400,000 Ci Co-60 in removable carrier
8. Safety cable plugs used in both vent and drain tube
9. Warning plate: "Safety cable plugs must be used when shipping container loaded"

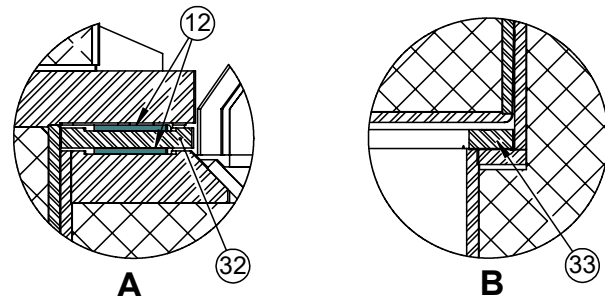
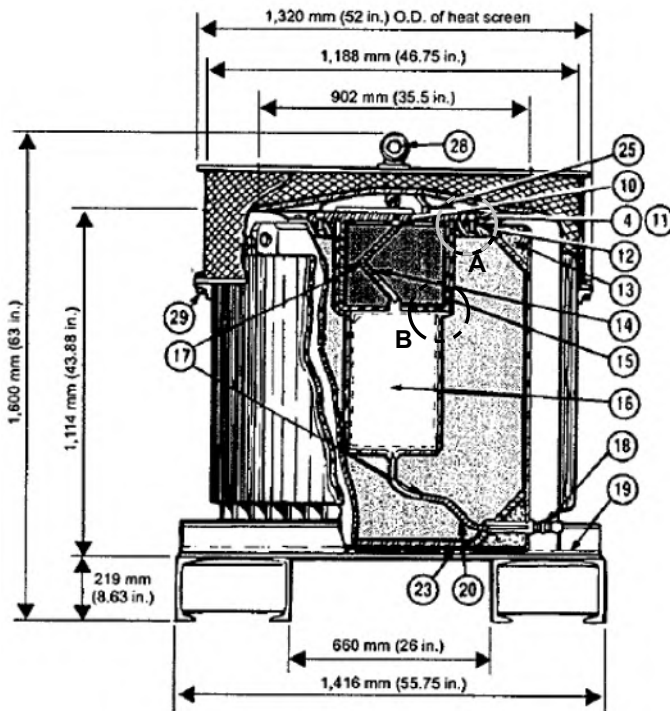

F-231-L CONFIGURATION

PREVIOUS VERSION NUMBER: IN/SS 1305 F231, ISSUE 15



447 March Road,
Ottawa, On K2K 1X8
Canada
Tel: (613) 592-2790
Fax: (613) 592-6937

TITLE

**F-231 & F-231-L TRANSPORT PACKAGES
(To IAEA 1973 Transport Regulations)**

File: F502001-002	ISSUE A	REVISED	CF 9194
CREATED	2019-12-12	Package No:	F-231 (1973)
DRAWN J. KAPLON	CHECKED C. CHALMERS	APPROVED J. CHAISSON	
SHEET		1 OF 1	

THIS DRAWING IS THE PROPERTY OF NORDION AND IS SUBMITTED FOR CONSIDERATION ON THE UNDERSTANDING THAT THERE SHALL BE NO EXPLOITATION OF ANY INFORMATION CONTAINED HEREIN EXCEPT WITH THE SPECIFIC WRITTEN AGREEMENT OF NORDION.



U.S. Department of
Transportation

**Pipeline and
Hazardous Materials
Safety Administration**

East Building, PHH-23
1200 New Jersey Ave, SE
Washington, D.C. 20590

CERTIFICATE NUMBER: USA/0348/B(U)-85

ORIGINAL REGISTRANT(S) :

Nordion (Canada) Inc.
447 March Road
Ottawa, Ontario, K2K 1X8
Canada

REGISTERED USERS:

Department of Energy
U.S. Department of Energy
1000 Independence Ave, SW
EM-60
Washington, DC, 20585
USA