



U.S. Department of
Transportation
**Pipeline and
Hazardous Materials
Safety Administration**

East Building, PHH-23
1200 New Jersey Ave, SE
Washington, D.C. 20590

June 23, 2021

Dr. James M. Shuler
Manager, Packaging Certification Program
Department of Energy
U.S. Department of Energy
1000 Independence Ave, SW
EM-60
Washington, DC, 20585
USA

Dear Dr. James M. Shuler,

As your June 18, 2021 letter requested, Department of Energy has been registered as a user of IAEA Certificate of Competent Authority USA/0214/B(U)-85 for the MDS Nordion F-168-X Shipping Flask, Serial Nos. 22-X, 23-X, 24-X, 25-X, 26-X, 41-X. This certificate, which revalidates the Canadian Certificate of Competent Authority No.2045 authorizes the transport of the package from the point of entry to final destination in the United States, from point of origin in the United States to point of exit, and through the United States.

A copy of the certificate is enclosed. All future revisions of the certificate will be forwarded to Department of Energy at James.Shuler@em.doe.gov.

Sincerely,

A handwritten signature in blue ink, appearing to read "Richard W. Boyle".

Richard W. Boyle, Chief
Radioactive Materials Branch
Office of Engineering and Research



U.S. Department
of Transportation

Pipeline and
Hazardous Materials
Safety Administration

East Building, PHH-23
1200 New Jersey Ave, SE
Washington, D.C. 20590

**COMPETENT AUTHORITY CERTIFICATION FOR A
TYPE B(U)**

**RADIOACTIVE MATERIALS PACKAGE DESIGN
CERTIFICATE USA/0214/B(U) , REVISION 17**

**REVALIDATION OF CANADIAN COMPETENT AUTHORITY
CERTIFICATE CDN/2045/B(U)**

The Competent Authority of the United States certifies that the radioactive material package design described in this certificate satisfies the regulatory requirements for a Type B(U) package as prescribed in the regulations of the International Atomic Energy Agency¹ and the United States of America² The package design is approved for use within the United States for import and export shipments made in accordance with applicable international and domestic transport regulations.

1. Package Identification - MDS Nordion F-168-X Shipping Flask, Serial Nos. 22-X, 23-X, 24-X, 25-X, 26-X, 41-X.
2. Package Description and Authorized Radioactive Contents - as described in Canadian Certificate of Competent Authority CDN/2045/B(U), 20 (attached).
3. General Conditions -
 - a. Each user of this certificate must have in his possession a copy of this certificate and all documents necessary to properly prepare the package for transportation. The user shall prepare the package for shipment in accordance with the documentation and applicable regulations.
 - b. Each user of this certificate, other than the original petitioner, shall register his identity in writing to the Office of Engineering and Research, (PHH-23), Pipeline and Hazardous Materials Safety Administration, U.S. Department of Transportation, Washington D.C. 20590-0001.

¹ "Regulations for the Safe Transport of Radioactive Material, 2012 Edition, No. SSR-6" published by the International Atomic Energy Agency (IAEA), Vienna, Austria.

² Title 49, Code of Federal Regulations, Parts 100-199, United States of America.

CERTIFICATE USA/0214/B(U) , REVISION 17

- c. This certificate does not relieve any consignor or carrier from compliance with any requirement of the Government of any country through or into which the package is to be transported.
 - d. Records of Management System activities required by Paragraph 306 of the IAEA regulations¹ shall be maintained and made available to the authorized officials for at least three years after the last shipment authorized by this certificate. Consignors in the United States exporting shipments under this certificate shall satisfy the applicable requirements of Subpart H of 10 CFR 71.
4. Marking and Labeling - The package shall bear the marking USA/0214/B(U) in addition to other required markings and labeling.
5. Expiration Date - This certificate expires on April 30, 2025. Previous editions which have not reached their expiration date may continue to be used.

This certificate is issued in accordance with paragraph(s) 820 of the IAEA Regulations and Section 173.473 of Title 49 of the Code of Federal Regulations, in response to the March 29, 2020 petition by Nordion (Canada) Inc., Ottawa, Ontario, and in consideration of other information on file in this Office.

Certified By:



William Schoonover
Associate Administrator for Hazardous
Materials Safety

April 01, 2020
(DATE)

Revision 17 - Issued to revalidate Canadian Certificate of Competent Authority No. CDN/2045/B(U), Revision 20, and to extend the expiration date.



Certificate

CDN/2045/B(U) (Rev. 20)

Transport Package Design

The transport package design identified below is certified by the Canadian Nuclear Safety Commission pursuant to paragraph 21(1)(h) of the *Nuclear Safety and Control Act* and Subsection 10(1) of the *Packaging and Transport of Nuclear Substances Regulations, 2015* and to the 1973 Revised Edition (as amended) of the IAEA's *Regulations for the Safe Transport of Radioactive Material*.

REGISTRATION OF USE OF PACKAGES

All users of this authorization shall register their identity in writing with the Canadian Nuclear Safety Commission prior to the first use of this authorization and shall certify that they possess the instructions necessary for preparation of the package for shipment.

PACKAGE IDENTIFICATION

Designer: **Nordion (Canada) Inc.**
Make/Model: **F-168-X Shipping Flask, Serial Nos. 22-X, 23-X, 25-X, 41-X**
Mode of Transport: **Air, Sea, Road, Rail**

IDENTIFICATION MARK

The package shall bear the competent authority identification mark "**CDN/2045/B(U)**".

PACKAGE DESCRIPTION

The F-168-X package, as shown on drawing nos. F116801-100 (Rev. F) and F116801-101 (Rev. J), consists of a lead-filled (266 mm thick lead shielding) steel-encased right cylinder with external fins, insulated steel flame shields on the top and side and steel-covered insulation on the bottom. The package is permanently mounted on a structural steel base. The containment system is the source assembly.

An illustration of the package is shown on attached Drawing No. F-168-X (IN/SS 1928 F168X) (Rev. 6).

Any modification to the package design must be submitted to the Canadian Nuclear Safety Commission for approval prior to implementation.



The configuration of the package is as follows:

Shape:	Cylinder	Shielding:	Lead
Mass:	5445 kg	Outer Casing:	Steel
Length:	1372 mm	Height:	1659 mm
Width:	1372 mm	Diameter:	1013 mm

AUTHORIZED RADIOACTIVE CONTENTS

This package is authorized to contain not more than 7,400 TBq (200,000 Ci) of Cobalt 60 in the form of metal, pellets, metal wafers, metal slugs, stainless steel clad wire, or aluminium clad cobalt slugs. The maximum decay heat is 3,200 watts.

The authorized models of the capsules that may be contained in this package are C132, C133, C146, C151, C177, C185, C188, C189, C190, C198, C199, C200, C238, TC239, C246, C247, C248, C252, C306, C335, XC318, XC325, C348, AC191, AC195, AC345, AC339 or any other welded stainless-steel capsules that meet the requirements of the International Organization of Standardization International Standard 2919 (First Edition) under classification number E53434.

QUALITY ASSURANCE

Quality assurance for the design, manufacture, testing, documentation, use, maintenance and inspection of the package shall be in accordance with:

- Nordion document entitled "MDS Nordion No. IN/QA 0224 Z000 (12)*, Radioactive Material Transport Package Quality Plan"
- Nordion document entitled "MDS Nordion No. IN/OP 0019 Z000 (14)*, Radioactive Material Transport Packaging Inspection and Maintenance Procedure"
- Packaging and Transport of Nuclear Substances Regulations, 2015
- IAEA Regulations for the Safe Transport of Radioactive Material, 2012 Edition
- * or latest current revision

SHIPMENT

The preparation for shipment of the package shall be in accordance with:

- Nordion document entitled "MDS Nordion No. IN/PP 0517 F168 (17), Preparation for Shipment of the F-168 and F-168-X Transport Packagings"
- Packaging and Transport of Nuclear Substances Regulations, 2015



- IAEA Regulations for the Safe Transport of Radioactive Material, 2012 Edition

The average surface heat flux of the package with 7,400 TBq of Cobalt 60 is 493 W/m². For heat fluxes exceeding 15 W/m², supplementary arrangements must be made with the carrier to ensure adequate heat dissipation.

Air transport is restricted to a maximum of 1,200 TBq of Cobalt 60 to meet the 3000 A₂ value and the temperature requirement of Paragraphs 433 and 619 of the IAEA Regulations.

This certificate does not relieve the consignor from compliance with any requirement of the government of any country through or into which the package will be transported.

K. Owen-Whitred

K. Owen-Whitred
Designated Officer pursuant to paragraph 37(2)(a)
of the Nuclear Safety and Control Act

Parts List

1. Upper fireshield
2. Holes for ventilation
3. Retaining brackets (4) for upper fireshield
4. Radiation caution plate (2)
5. Identification plate (2)
6. Fireshield (removable) - laminated construction: 2 x 6.3 mm (0.25 in.) Steel + 25.4 mm (1 in.) Kaowool, O.D. 1,013 mm (39.88 in.)
7. Warning plate "CAUTION - HEAT EMITTER - DO NOT STORE IN INSULATED OR REFRIGERATION CONTAINER OR INSULATED SPACE" (2)
8. Transite - steel encased
9. Vermiculite packing
10. Gasket (Neoprene)
11. 7/8 - 9 x 2 in. long hex bolt (8)
12. Wire seal
13. 3/8 in. NPT pipe plug (2)
14. Plug lift lug
15. Vent tube (sealed off at cavity)
16. Plug
17. Cavity: 479 mm x 162 mm dia. (18.87 in. x 6.37 in. dia.)
18. Radioactive contents and carrier
19. Drain tube (sealed off at cavity)
20. 3/4 -10 x 2 in. hex bolt for Skid (4)
21. Removable shipping skid, 1,372 mm (54 in.) square
22. Standard pipe plug (sealed off)
23. Category label (2): on two opposite sides
24. UN Number Label (2): one next to each of the radioactive category labels

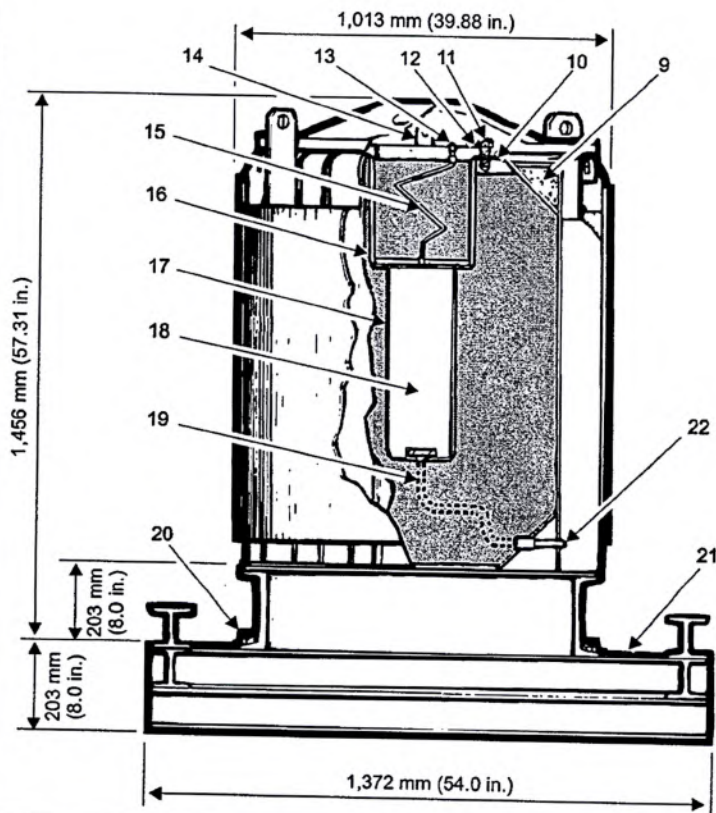
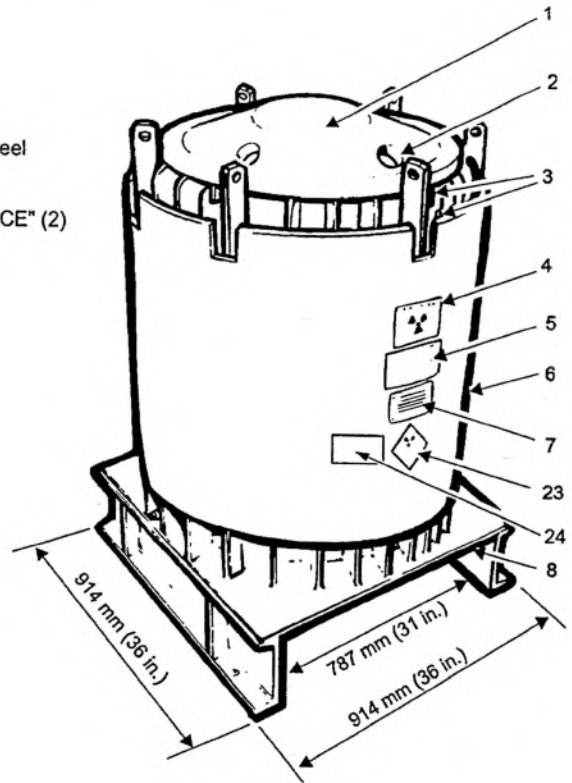

Notes

1. CNSC certificate CDN/2045/B(U)
2. Meets IAEA Type B(U) requirements
3. Steel encased lead shielding: 266 mm (10.5 in.)
4. Gross weight: 5,445 kg (12,000 lb.)
5. Plug weight: 177 kg (390 lb.)
6. Projected floor loading: 2,900 kg/m² (593 lb/ft²)
7. Radionuclides carried: Cobalt-60
8. Labels may be positioned as illustrated, or 45° to that shown

MDS Nordion

447 March Road, P.O. Box 13500
 Kanata, Ontario, Canada, K2K 1X8
 Tel: (613) 592-2790 · Fax: (613) 592-6937

TITLE

F-168-X Transport Packaging

THIS DRAWING IS THE PROPERTY OF MDS NORDION AND IS SUBMITTED FOR CONSIDERATION ON THE UNDERSTANDING THAT THERE SHALL BE NO EXPLOITATION OF ANY INFORMATION CONTAINED HEREIN EXCEPT WITH THE SPECIFIC WRITTEN AGREEMENT OF MDS NORDION.

REF. IN/SS 1928 F168X F116801-100/F116801-101		REVISED May 03	DCN A1944-D-04A
DATE 1980 August	No. F-168-X		ISSUE 6
DRAWN <i>BW</i>	CHECKED <i>AD</i>	APPROVED <i>ML</i>	SHEET 1 OF 1



Canada's Nuclear Regulator
L'organisme de réglementation
nucléaire du Canada

NOTES

Revision 19: February 22, 2016. Certificate renewed.

Revision 20: March 25, 2020. Certificate renewed.



Canadian Nuclear
Safety Commission

Commission canadienne
de sûreté nucléaire

Canada



U.S. Department of
Transportation

**Pipeline and
Hazardous Materials
Safety Administration**

East Building, PHH-23
1200 New Jersey Ave, SE
Washington, D.C. 20590

CERTIFICATE NUMBER: USA/0214/B(U)-85

ORIGINAL REGISTRANT(S) :

Best Theratronics Ltd.
413 March Road
Ottawa, Ontario, K2K 0E4
CANADA

Sterigenics
10811 Withers Cove Park Drive
Charlotte, NC, 28278
USA

Nordion (Canada) Inc.
447 March Road
Ottawa, Ontario, K2K 1X8
Canada

REGISTERED USERS:

Department of Energy
U.S. Department of Energy
1000 Independence Ave, SW
EM-60
Washington, DC, 20585
USA