

FCF 1325.5

United States Government

Department of Energy

memorandum

Rocky Flats Field Office

DATE: **AUG 19 1999**REPLY TO:
ATTN OF: AMFD:FCG:DAH:01920

SUBJECT: Request for Approval to Use the DOT-6M Container for Shipment of Plutonium Metal

TO: Michael E. Wangler, Director, Package Certification and Transportation Safety
Program, EM-70, HQ

The Rocky Flats Environmental Technology Site (Site) plans to ship plutonium metal materials to the Savannah River Site, the Los Alamos National Laboratory, and the Lawrence Livermore National Laboratory. The metal forms planned for shipment to these facilities include buttons and materials derived from classified shapes and ingots. The quantity of material that will be packaged in each container will exceed 20 curies. The shipping container planned to be used for these shipments is the DOT-6M. The attached correspondence provides additional information concerning the packaging procedures that will be used for these shipments.

In accordance with DOE Order 460.1, Paragraph 4.a.(4)(c), the Rocky Flats Field Office requests your approval for the Site's use of the DOT-6M for shipments of plutonium metal exceeding 20 curies. If you have any question or would like additional information, please contact me at (303) 966-3122.



David Alan Hicks
Facilities Closure Group

Attachment

Post-it* Fax Note	7671	Date	8-19-99	# of pages	6
To	MIKE Wangler	From	DOVE HICKS		
Co./Dept	EM-70	Co.	RFRO		
Phone #	5078	Phone #	303 966 3122		
Fax #	303 903 9691	Fax #	2497		

Michael F. Wangler
AMFD:FCG:DAH:01920

2

cc:

- P. Bubar, EM-63, HQ
- B. Smith, EM-64, HQ.
- A. Guevara, EM-64, HQ
- II. Dalton, AMFD, RFFO
- R. Sena, AL, NMSPO
- D. Gurule, LAAO
- J. Turner, OAK
- A. Gunter, SRO
- G. Rudy, SRO
- J. Brown, LANL
- C. Tartar, LLNL
- J. Anderson, WSRC
- J. Fulton, K-H



August 17, 1999

99-RF-03247

David A. Hicks
Nuclear Facilities Closure Group
DOE, RFFO

**USE OF THE DEPARTMENT OF TRANSPORTATION (DOT)-6M SHIPPING CONTAINER
FOR PLUTONIUM METAL - RCL-031-99**

The purpose of this letter is to request approval to use the DOT-6M shipping container for offsite shipments of Plutonium Metal. The Kevin Ryan to Robert Leonard letter "DOT 6M Approval For Plutonium Metal and Alloy Shipments" dated July 30, 1999 (attached) requests approval for use of this shipping container for Plutonium metal over 20 Curies.

Kaiser-Hill Company, L. L. C. agrees with this request and believes the DOT-6M to be a safe and effective container for shipping Plutonium Metal over 20 Curies. The next scheduled shipment is planned for Plutonium "Buttons" to Los Alamos National Laboratory within a month of this letter. Please forward this request for the timely approval for use of the DOT-6M packaging by the Headquarters Certifying Official.

If you have any questions please contact me at x4889.



Bob Leonard
Nuclear Operations,
Kaiser-Hill Company, L.L.C.

RCL:pja

Attachment:
As Stated

cc:
Matt McCormick – w/o attach.
Larry Wilson – w/o attach.

Kaiser-Hill Company, L.L.C.

Courier Address: Rocky Flats Environmental Technology Site, State Hwy. 93 and Cactus, Rocky Flats, CO 80007 • 303.966.7000

Mailing Address: P.O. Box 464, Golden, Colorado 80402-0464



July 30, 1999

99-RF-03023

Robert C. Leonard
Director
SNM Shipping and Consolidation
Kaiser-Hill, L.L.C.

DOT 6M APPROVAL FOR PLUTONIUM METAL AND ALLOY SHIPMENTS – KER-102-99

The purpose of this letter is to request approval pursuant to DOE Order 460.1, paragraph 4.a.(4)(c) 1, which requires approval by the Headquarters Certifying Official for packagings containing over 20 curies of plutonium. Specifically, this request is for approval to ship Rocky Flats Environmental Technology Site (RFETS) plutonium metal and alloy to the Savannah River Site, Los Alamos National Laboratory, and Lawrence Livermore National Laboratory in the DOT-6M packaging.

The plutonium metal and alloys are greater than 50 gram pieces of metal that resulted from production operations at RFETS. They may be in the form of buttons, sized ingots, or sized classified shapes.

These pieces meet the definition of solid plutonium metal alloy, as identified in 10CFR71.63(b)(2) and, therefore, are exempt from the requirement of double containment.

A sketch of the inner packaging is shown on the attachment. The metal is contained in the 404X414 or 401X509 steel, crimp-sealed inner produce can. This can is sealed in a nylon, PVC, or polyethylene (PE) bag-out bag. The bagged can is then crimp-sealed in a 408x608 steel produce can. An optional 404X700 outer can may be used.

The 6M containers to be used for shipment all include DOT-2R containment vessels that have been certified to have passed the load and leak tests performed to locate bad welds as specified by the Container Weld Advisory Committee.

All shipments will be made in conformance with 49CFR 173.417, including limitation of heat load to 10 watts and plutonium mass to 4.5 kilograms per package.

These materials will be shipped as part of the efforts to de-inventory RFETS, with the next shipment planned for August 1999. Timely approval for use of the DOT 6M packaging by the Headquarters Certifying Official is hereby requested.

REMOVED FOR CLASSIFICATION

By A. J. Brouch
Date 7-30-99 

R. C. Leonard
July 30, 1999
99-RF-03023
Page 2

If there are any questions, please contact Paul Clark at extension 4383, Don Thorp at extension 3410, or Rick Geinitz at extension 5115.

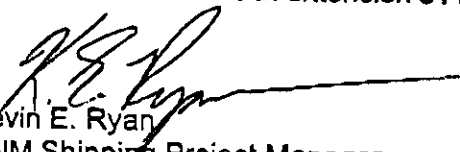

Kevin E. Ryan
SNM Shipping Project Manager
Safe Sites of Colorado, L.L.C.

DTT:eyk

Attachments:
As Stated (1)

cc:
P. B. Clark, LATA
R. R. Geinitz, SSOC
L. F. Giron, SSOC
G. W. Jackson, SSOC
D. T. Thorp, SSOC

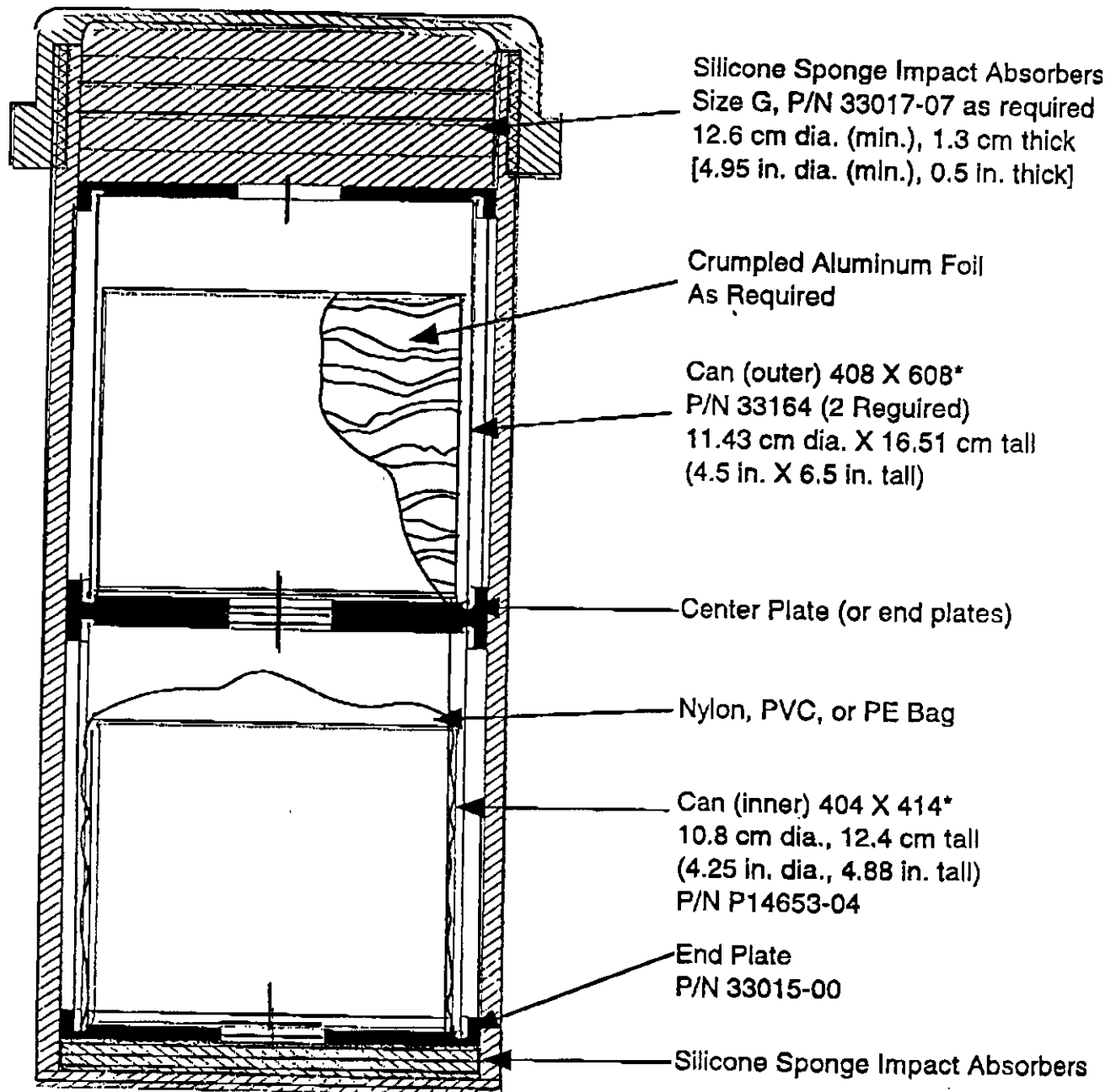
DOT Specification 2R Vessel-Pu Metal & Alloy
(Per 49 CFR 178.360)

* optional 404 x 509 Inner Can, or optional 404 x 700 outer can