



U.S. Department  
of Transportation

Pipeline and  
Hazardous Materials  
Safety Administration

East Building, PHH-23  
1200 New Jersey Ave, SE  
Washington, D.C. 20590

IAEA CERTIFICATE OF COMPETENT AUTHORITY  
SPECIAL FORM RADIOACTIVE MATERIALS

CERTIFICATE USA/0759/S-96, REVISION 3

This certifies that the sources described have been demonstrated to meet the regulatory requirements for special form radioactive material as prescribed in the regulations of the International Atomic Energy Agency<sup>1</sup> and the United States of America<sup>2</sup> for the transport of radioactive material.

1. Source Identification - Eckert & Ziegler Isotope Products Source Capsule Model LWD Series.
2. Source Description - Cylindrical double encapsulations made of MP35N alloy and fusion seal welded. Approximate outer dimensions are either 14.3 mm (0.56 in.) in diameter and 63.5 mm (2.50 in.) in length (Capsule 4133) or 22.0 mm (0.87 in.) in diameter and 73.3 mm (2.89 in.) in length (Capsule 4173). Construction of LWD Series Capsules shall be in accordance with attached Eckert & Ziegler Isotope Products Drawing Nos. 4133-REG, Rev. A, Sheet 1 of 1 or 4173-REG, Rev. -, Sheet 1 of 1.
3. Radioactive Contents - No more than 740 GBq (20 Ci) of Americium-241. The Am-241 is in the form of an oxide mixed with beryllium, compressed as a pellet in a metal matrix.
4. Management System Activities - Records of Management System activities required by Paragraph 306 of the IAEA regulations shall be maintained and made available to the authorized officials for at least three years after the last shipment authorized by this certificate. Consignors in the United States exporting shipments under this certificate shall satisfy the requirements of Subpart H of 10 CFR 71.

---

<sup>1</sup> "Regulations for the Safe Transport of Radioactive Material, 2012 Edition, No. SSR-6" published by the International Atomic Energy Agency (IAEA), Vienna, Austria.

<sup>2</sup> Title 49, Code of Federal Regulations, Parts 100-199, United States of America.

**CERTIFICATE USA/0759/S-96, REVISION 3**

5. Expiration Date - This certificate expires on June 30, 2023. Previous editions which have not reached their expiration date may continue to be used.

This certificate is issued in accordance with paragraph(s) 804 of the IAEA Regulations and Section 173.476 of Title 49 of the Code of Federal Regulations, in response to the May 31, 2018 petition by Eckert & Ziegler Isotope Products, Valencia, CA, and in consideration of other information on file in this Office.

Certified By:



June 11, 2018  
(DATE)

 William Schoonover  
Associate Administrator for Hazardous  
Materials Safety

Revision 3 - Issued to update the attached drawings and to extend the expiration date.

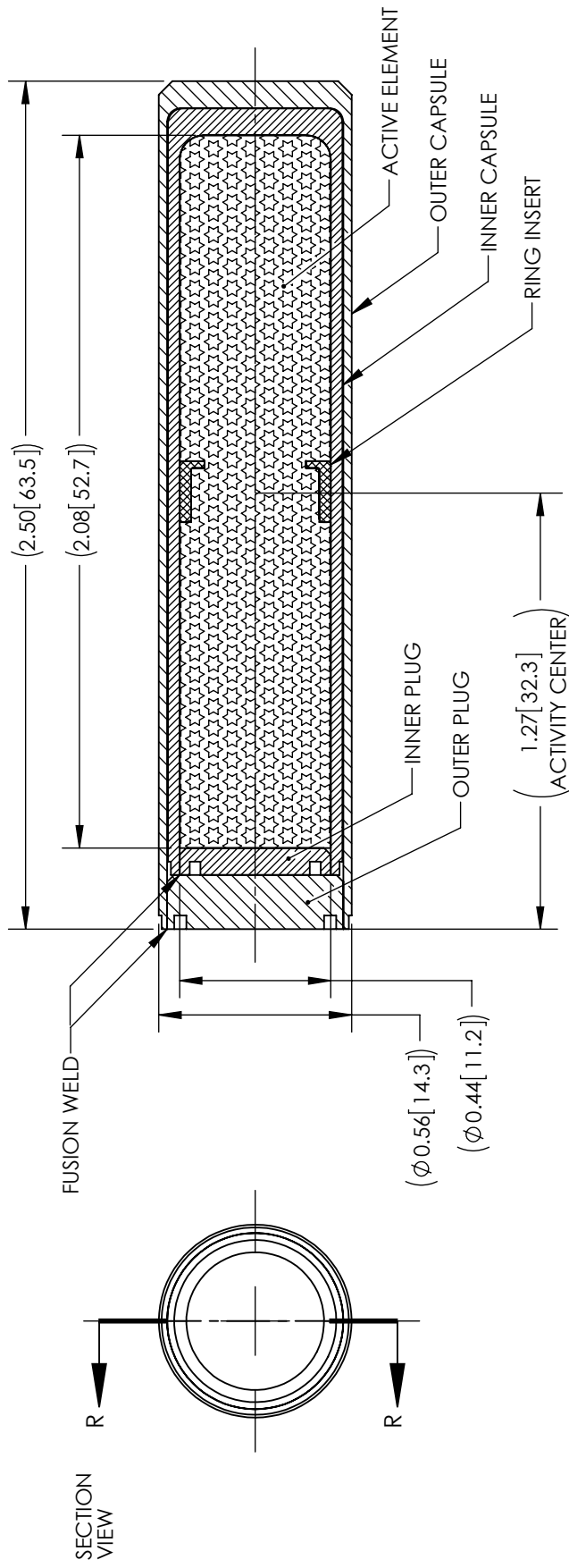

MINIMUM CAPSULE ENGRAVING:  
 "RADIOACTIVE" OR   
 "RADIATION SYMBOL,"  
 "NUCLIDE ACTIVITY,"  
 "SERIAL NO.,"  
 "MANUFACTURER, MODEL NO."

ON REVERSE SIDE OF SOURCE  
 (NOT SHOWN);  
 "TREFOIL SYMBOL AND/OR WORDING,"  
 "DANGER (OR CAUTION) RADIOACTIVE  
 MATERIAL."

 <b>Eckert &amp; Ziegler</b> <b>Isotope Products</b> VALENCIA, CALIFORNIA 91355	CAGE CODE	32993	DRAWING SIZE	LETTER	DRAWN	TITLE	
	UNLESS OTHERWISE SPECIFIED DIMENSIONS ARE IN INCH SIZES. METRIC UNITS [mm] ARE IN MILLIMETERS.				KP	MODEL LWD SERIES (CAPSULE 4133)	
THIS DRAWING IS THE PROPERTY OF ECKERT & ZIEGLER ISOTOPE PRODUCTS AND MAY NOT BE USED, REPRODUCED, PUBLISHED OR DISCLOSED TO OTHERS WITHOUT EXPRESS AUTHORIZATION BY ECKERT & ZIEGLER ISOTOPE PRODUCTS.	TOLERANCES (UNLESS OTHERWISE SPECIFIED)	± .002 INCH	ANGULAR TOLERANCE OF 0°-60°	ENGINEER	SERIES TITLE		
	X.XX ± .005 INCH	INCH	FRACTIONAL DIMENSIONS ± 1/32"	KP	OIL WELL LOGGING (Am-Be GROUP)		
	X.X ± .03 INCH	INCH	REFERENCE DIMENSIONS (I) N/A	SCALE	4133-REG	REV	A
	X. ± .1 INCH	INCH	SURFACE ROUGHNESS (INCH) MAX	2:1	DRAWING NO.	REV	SHEET
							1 OF 1

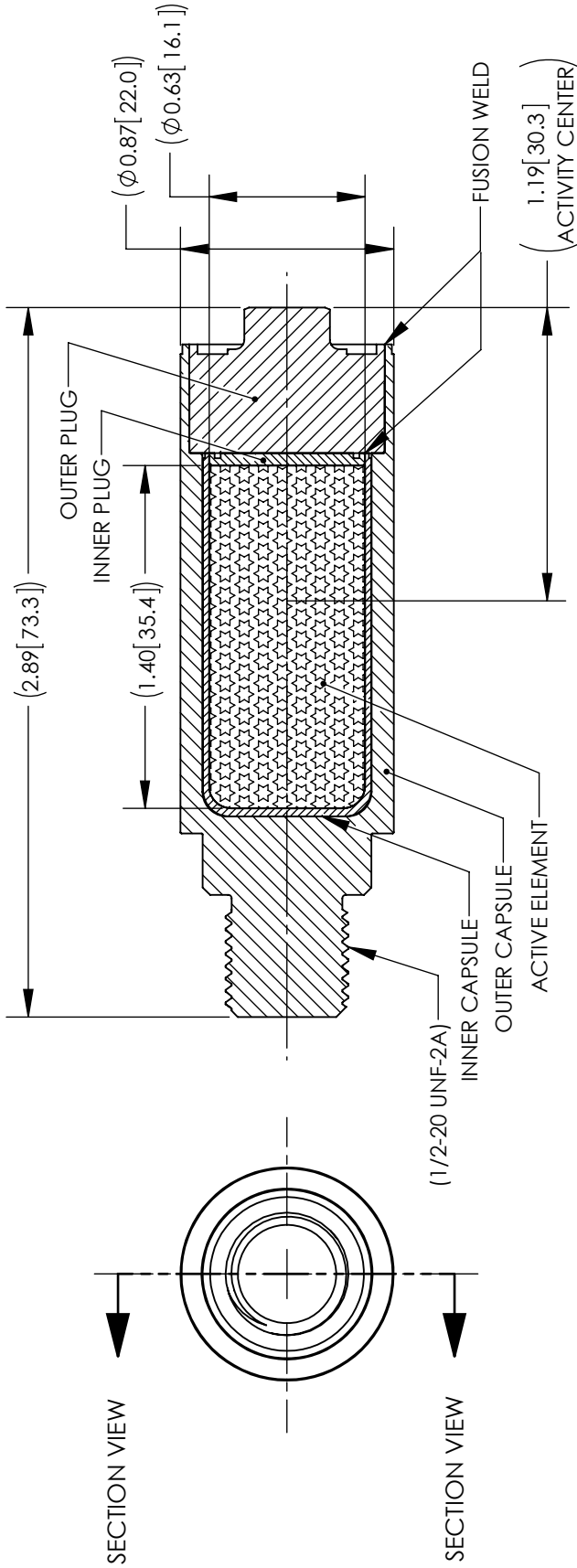

SECTION VIEW

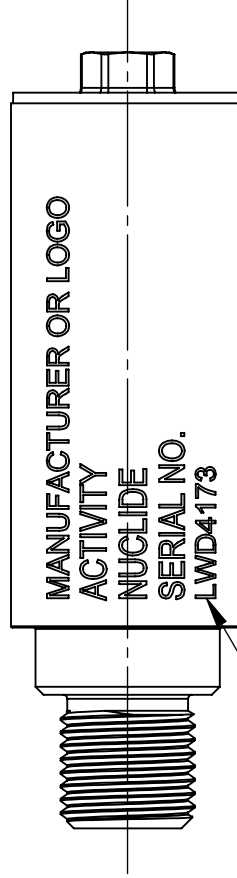

MODEL VIEW (NOT TO SCALE)

MINIMUM CAPSULE ENGRAVING:  
 "RADIOACTIVE" OR  
 RADIATION SYMBOL,  
 NUCLIDE, ACTIVITY,  
 SERIAL NO.,  
 MANUFACTURER, MODEL NO.  
 ON REVERSE SIDE OF SOURCE (NOT SHOWN): TREFOIL SYMBOL AND/OR WORDING,  
 "DANGER (OR CAUTION) RADIOACTIVE MATERIAL"



	<b>Eckert &amp; Ziegler</b> <b>Isotope Products</b>		VALENCIA, CALIFORNIA 91355	
	<small>THIS DRAWING IS THE PROPERTY OF ECKERT &amp; ZIEGLER ISOTOPE PRODUCTS AND MAY NOT BE USED, REPRODUCED, PUBLISHED OR DISCLOSED TO OTHERS WITHOUT EXPRESS AUTHORIZATION BY ECKERT &amp; ZIEGLER ISOTOPE PRODUCTS.</small>			
CAGE CODE	32993	DRAWING SIZE	LETTER	SCALE
<small>UNLESS OTHERWISE SPECIFIED DIMENSIONS ARE IN INCH SIZES. METRIC UNITS [mm] ARE IN MILLIMETERS.</small>		<small>TOLERANCES (UNLESS OTHERWISE SPECIFIED)</small> X.XXX ± .002 INCH ANGULAR TOLERANCE OF 0°±30' X.XX ± .005 INCH FRACTIONAL DIMENSIONS ± 1/32" X.X ± .03 INCH REFERENCE DIMENSIONS (I) N/A X. ± .1 INCH SURFACE ROUGHNESS (INCH) MAX	DRAWN: KP ME/CHECKER: JH ENGINEER: KP	1:4:1
TITLE: MODEL LWD SERIES (CAPSULE 4173)		SERIES TITLE: OIL WELL LOGGING (Am-Be GROUP)		
DRAWING NO.: 4173-REG		REV: -	SHEET: 1 OF 1	



U.S. Department of  
Transportation

**Pipeline and  
Hazardous Materials  
Safety Administration**

East Building, PHH-23  
1200 New Jersey Ave, SE  
Washington, D.C. 20590

**CERTIFICATE NUMBER:** USA/0759/S-96

**ORIGINAL REGISTRANT(S) :**

Eckert & Ziegler Isotope Products  
24937 Avenue Tibbitts  
Valencia, CA, 91355  
USA