



U.S. Department  
of Transportation  
**Pipeline and  
Hazardous Materials  
Safety Administration**

**COMPETENT AUTHORITY CERTIFICATION  
FOR A TYPE B(U)  
RADIOACTIVE MATERIALS PACKAGE DESIGN  
CERTIFICATE USA/0617/B(U)-96, REVISION 7**

East Building, PHH-23  
1200 New Jersey Avenue Southeast  
Washington, D.C. 20590

**REVALIDATION OF CANADIAN COMPETENT AUTHORITY  
CERTIFICATE CDN/2081/B(U)-96**

This certifies that the radioactive material package design described is hereby approved for use within the United States for import and export shipments only. Shipments must be made in accordance with the applicable regulations of the International Atomic Energy Agency<sup>1</sup> and the United States of America<sup>2</sup>.

1. Package Identification - MDS Nordion F-168 (1996) and F-168-X (1996), Serial Nos. 53 and up.
2. Package Description and Authorized Radioactive Contents - as described in Canada Certificate of Competent Authority CDN/2081/B(U)-96, Revision 4 (attached). Contents must be in source capsules that meet IAEA special form requirements or have been shown to meet ISO 2919 classification E53424 or higher. All capsules must have been leak tested within six months prior to shipment, and must not have been damaged during their service life.
3. General Conditions -
  - a. Each user of this certificate must have in his possession a copy of this certificate and all documents necessary to properly prepare the package for transportation. The user shall prepare the package for shipment in accordance with the documentation and applicable regulations.
  - b. Each user of this certificate, other than the original petitioner, shall register his identity in writing to the Office of Hazardous Materials Technology, (PHH-23), Pipeline and Hazardous Materials Safety Administration, U.S. Department of Transportation, Washington D.C. 20590-0001.
  - c. This certificate does not relieve any consignor or carrier from compliance with any requirement of the Government of any country through or into which the package is to be transported.

---

<sup>1</sup> "Regulations for the Safe Transport of Radioactive Material, 1996 Edition (Revised), No. TS-R-1 (ST-1, Revised)," published by the International Atomic Energy Agency (IAEA), Vienna, Austria.

<sup>2</sup> Title 49, Code of Federal Regulations, Parts 100-199, United States of America.

**CERTIFICATE USA/0617/B(U)-96, REVISION 7**

- d. Records of Quality Assurance activities required by Paragraph 310 of the IAEA regulations<sup>1</sup> shall be maintained and made available to the authorized officials for at least three years after the last shipment authorized by this certificate. Consignors in the United States exporting shipments under this certificate shall satisfy the applicable requirements of Subpart H of 10 CFR 71.
4. Marking and Labeling - The package shall bear the marking USA/0617/B(U)-96 in addition to other required markings and labeling.
5. Expiration Date - This certificate expires on November 30, 2021.

This certificate is issued in accordance with paragraph 808 of the IAEA Regulations and Section 173.473 of Title 49 of the Code of Federal Regulations, in response to the September 19, 2016 petition by Nordion (Canada) Inc., Ottawa, Ontario, and in consideration of other information on file in this Office.

Certified By:



William Schoonover  
Acting Associate Administrator for Hazardous Materials Safety

**Oct 13 2016**  
(DATE)

Revision 7 - Issued to revalidate Canadian Certificate of Approval No. CDN/2081/B(U)-96, Revision 4.



# Certificate

**CDN/2081/B(U)-96 (Rev. 4)**

## Transport Package Design

The transport package design identified below is certified by the Canadian Nuclear Safety Commission pursuant to paragraph 21(1)(h) of the *Nuclear Safety and Control Act* and Subsection 10(1) of the *Packaging and Transport of Nuclear Substances Regulations, 2015* and to the IAEA's *Regulations for the Safe Transport of Radioactive Material, 2012 Edition*.

### REGISTRATION OF USE OF PACKAGES

All users of this authorization shall register their identity in writing with the Canadian Nuclear Safety Commission prior to the first use of this authorization and shall certify that they possess the instructions necessary for preparation of the package for shipment.

### PACKAGE IDENTIFICATION

Designer: **Nordion (Canada) Inc.**  
Make/Model: **F-168 (1996) and F-168-X (1996), Serial Nos. 53 and up**  
Mode of Transport: **Air, Rail, Road, Sea**

### IDENTIFICATION MARK

The package shall bear the competent authority identification mark "**CDN/2081/B(U)-96**".

### PACKAGE DESCRIPTION

The F-168 packaging, as shown on Nordion Drawing Nos. F116801-001, (Rev. X) and F116801-020, (Rev. H) and the F-168-X packaging, as shown on Nordion Drawing Nos. F116801-100 (Rev. F) and F116801-101 (Rev. J), consists of a 266 mm lead-filled shielding steel encased right cylinder with external fins, insulated steel flame shields on the top and side, steel covered insulation on the bottom and an optional heat screen on the top. The cavity is equipped with a drain and vent line for pool loading. The drain and vent line of the F-168-X package are sealed with a stainless steel plug. The package is permanently mounted on a structural steel base. The containment system is the source outer encapsulation. An illustration of the package is shown on attached Drawing No. F-168(-X) (1996) (Issue 2).

Any modification to the package design must be submitted to the CNSC for approval prior to implementation.



The configuration of the F-168 and F-168-X is as follows:

Shape: <b>Cylinder</b>	Shielding: <b>Lead</b>
Mass: <b>5445 kg</b>	Outer Casing: <b>Steel</b>
Length: <b>n/a</b>	Height: <b>1659 mm</b>
Width: <b>n/a</b>	Diameter: <b>1013 mm</b>

### **AUTHORIZED RADIOACTIVE CONTENTS**

See Appendix A

### **QUALITY ASSURANCE**

Quality assurance for the design, manufacture, testing, documentation, use, maintenance and inspection of the package shall be in accordance with:

- Nordion document entitled "MDS Nordion Specification No. IN/DS 1811 F-168 (2), Design, Manufacturing and Operating Specification for F-168 and F-168-X Transport Packages"
- Nordion Specification No. IN/QA 0224 Z000 (11)\*, "Radioactive Material Transport Package Quality Plan"
- Nordion document entitled "MDS Nordion Specification No. IN/QA 0562 A000 (4)\*, Sealed Source Quality Plan"
- Packaging and Transport of Nuclear Substances Regulations, 2015
- IAEA Regulations for the Safe Transport of Radioactive Material, 2012 Edition
- \* or latest current revision

### **SHIPMENT**

The preparation for shipment of the package shall be in accordance with:

- Nordion document entitled, "MDS Nordion Specification No. IN/DS 1811 F-168 (2), Design, Manufacturing and Operating Specification for F-168 and F-168-X Transport Packages"
- Packaging and Transport of Nuclear Substances Regulations, 2015
- IAEA Regulations for the Safe Transport of Radioactive Material, 2012 Edition



For shipment by air transport, the content of Cobalt-60 and Antimony-124 is limited to 1200 TBq and 1800 TBq respectively.

This certificate does not relieve the consignor from compliance with any requirement of the government of any country through or into which the package will be transported.

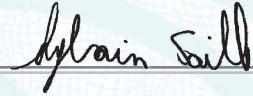

---

S. Faille

Designated Officer pursuant to paragraph 37(2)(a) of  
the Nuclear Safety and Control Act

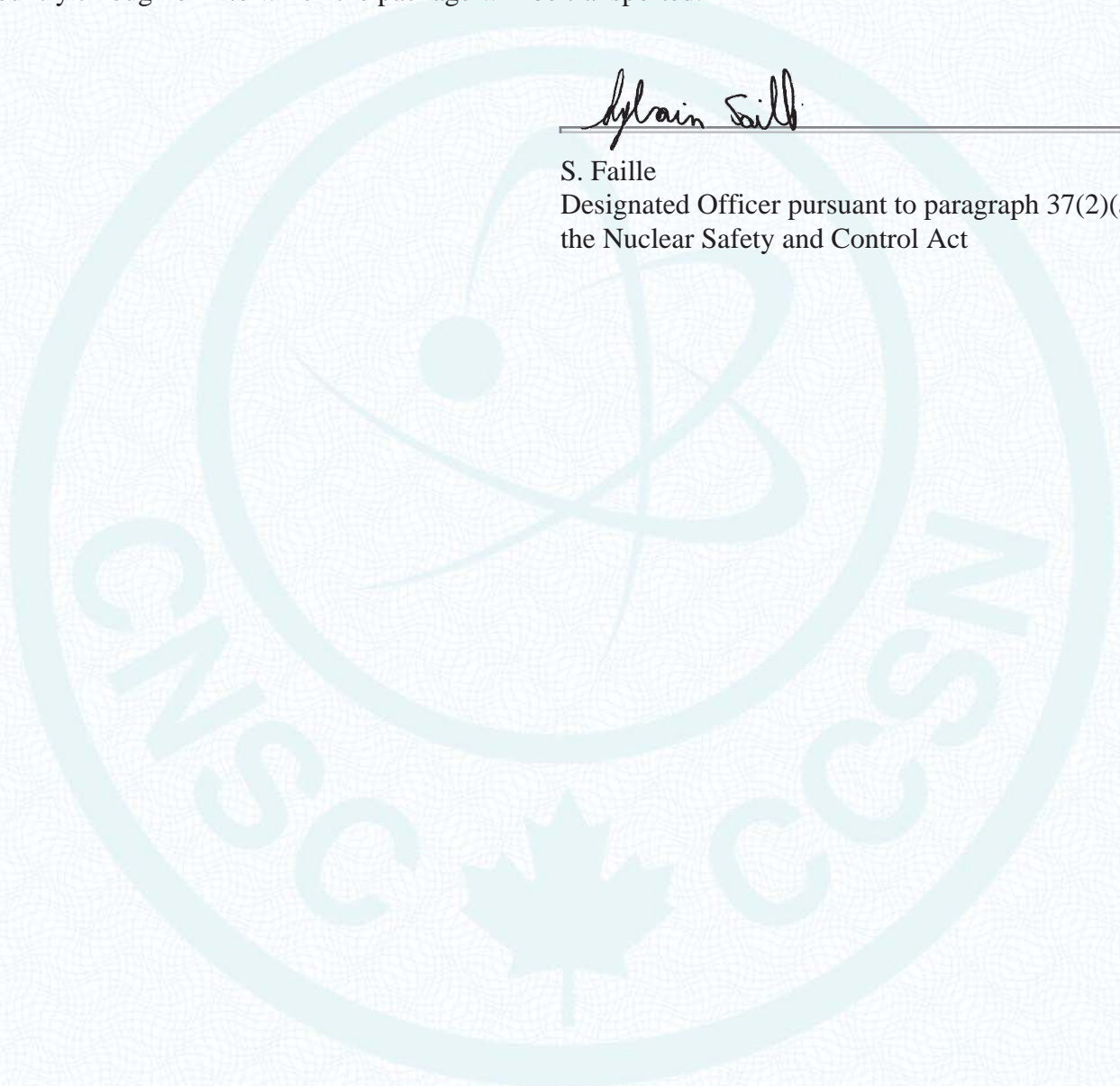



### Appendix A

The package is authorized to contain not more than:

Radionuclide	Maximum Quantity (TBq)	Form	Maximum Decay Heat (W)	Sealed Capsule
Cobalt-60	7400	Metal pellets, metal wafer, metal slug, stainless steel clad wire, aluminium clad cobalt slugs	3200	R-2089, RSL-2089, C-132, C-133, C-146, C-151, C-177, C-185, C-188, C-189, C-190, C-198, C-199, C-200, C-238, TC-239, C-246, C-247, C-248, C-252, C-306, C-335, XC-318, XC-325, C-348, C-442, AC-191*, AC-195*, AC-345*, AC-339*, welded stainless steel capsules that meet the requirements of the International Organization of Standardization International Standard 2919 (First Edition) under classification number E53424, or special form sources similar to source models listed above, all with the capsules retained within a holder that distribute them throughout the cavity volume.
Cobalt-60	2590	Metal slug aluminium sheathed	1070	C-350 or special form sources similar to the source models listed above, all with the capsules retained within a holder that distribute them throughout the cavity volume.
Cobalt-60	5550	Metal slug nickel plated	2320	C-351 or special form sources similar to the source models listed above, all with the capsules retained within a holder that distribute them throughout the cavity volume.
Antimony-124	1850	Cast metal	660	C-232 or special form sources similar to the source models listed above, all with the capsules retained within a holder that distribute them throughout the cavity volume.
Cesium-137	3700	Cesium chloride	522	Special form sources with double encapsulation in stainless steel, all with the capsules retained within a holder that distribute them throughout the cavity volume.

\* Transported in F-168-X only

Combination loading of the above materials is authorized provided that the sum of the ratios of loaded activity to authorized activity, for all material loaded, does not exceed 1.0.





## **NOTES**

Revision 3: September 11, 2012. Certificate re-issued.

Revision 4: September 16, 2016. Addition of source models R-2089 and RSL-2089 to the list of authorized radioactive contents.

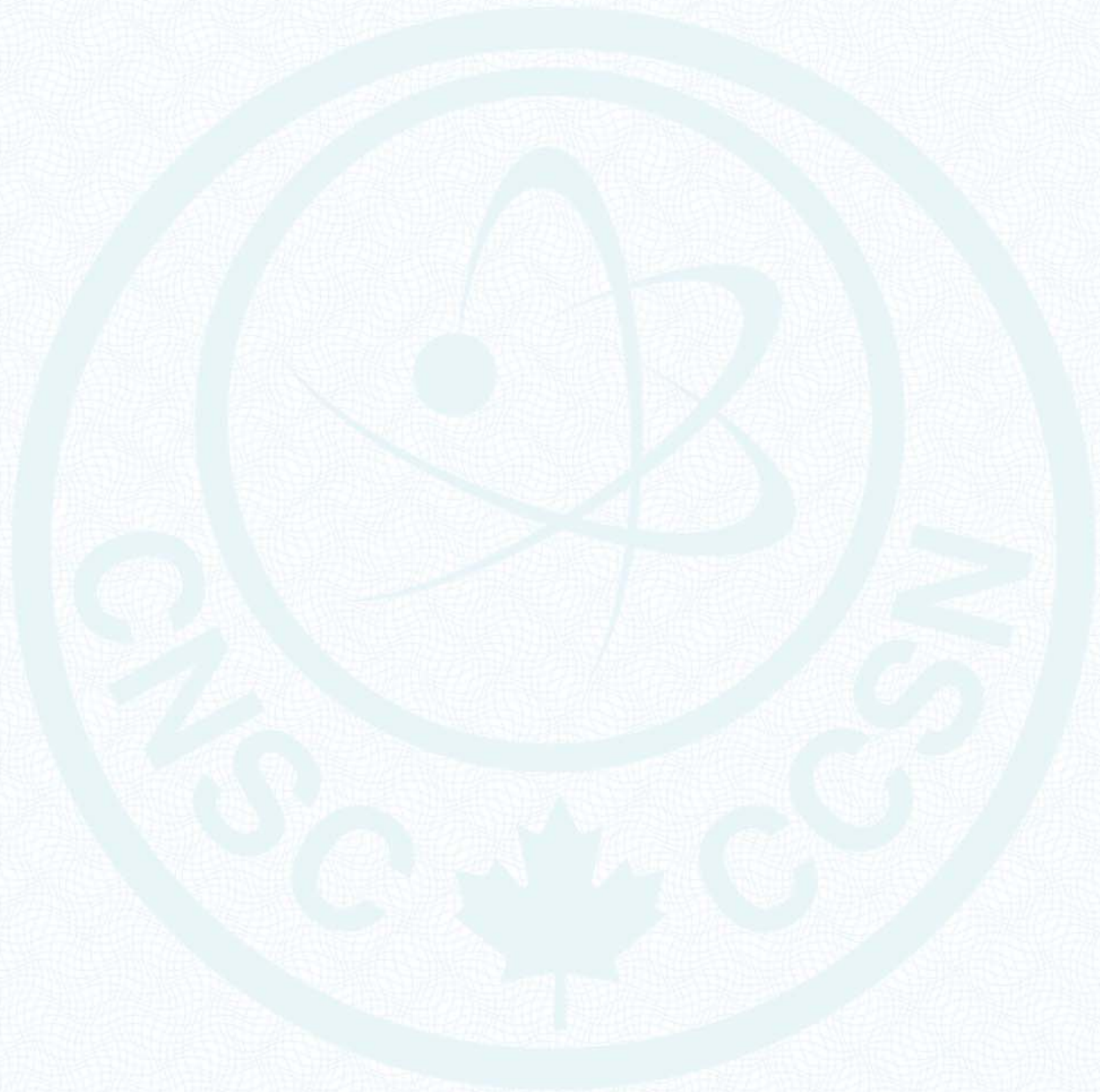

**Parts List**

1. Upper Fireshield
2. Optional Heat Screen
3. Retaining Brackets (4) for Upper Fireshield
4. Radiation Caution Plate
5. MDS Nordion Identification Plate
6. Fireshield (Removable) - O.D. 1013 mm (39.88 in.), Laminated Construction: 2 x 6.3 mm (0.25 in.) Steel + 25.4 mm (1 in.) Kaowool
7. Warning Plate "CAUTION - HEAT EMITTER - DO NOT STORE IN INSULATED OR REFRIGERATION CONTAINER OR INSULATED SPACE"
8. Ceramic insulation - Steel Encased
9. Vermiculite Packing
10. Gasket (Neoprene)
11. 7/8 - 9 Hex Bolt (8)
12. Wire Seal
13. 3/8 in. NPT Pipe Plug (2)
14. Plug Lift Lug
15. Vent Tube
16. Plug
17. Cavity: 479 mm x 162 mm Dia. (18.87 in. x 6.37 in. Dia.)
18. Radioactive Contents and Carrier
19. Drain Tube (sealed at cavity for F-168-X)
20. 3/4 - 10 Hex Bolt for Skid (4)
21. Optional Removable Shipping Skid, 54 in. (1370 mm) square
22. Nipple and Drainline Cap (sealed with standard pipe plug for F-168-X)
23. Shield Plate with 3/8 - 16 Screws (3)
24. Category Label (2)
25. Eye Bolt
26. Eye Bolt Cover
27. UN Number Label (2)

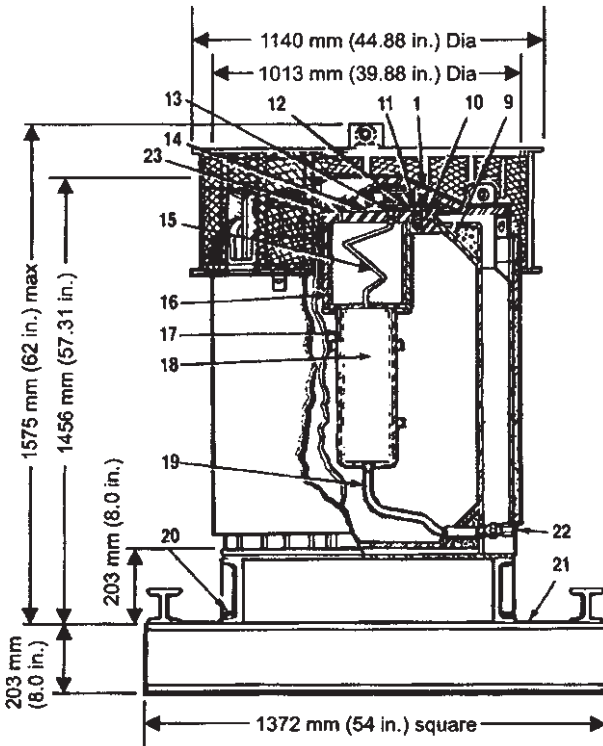
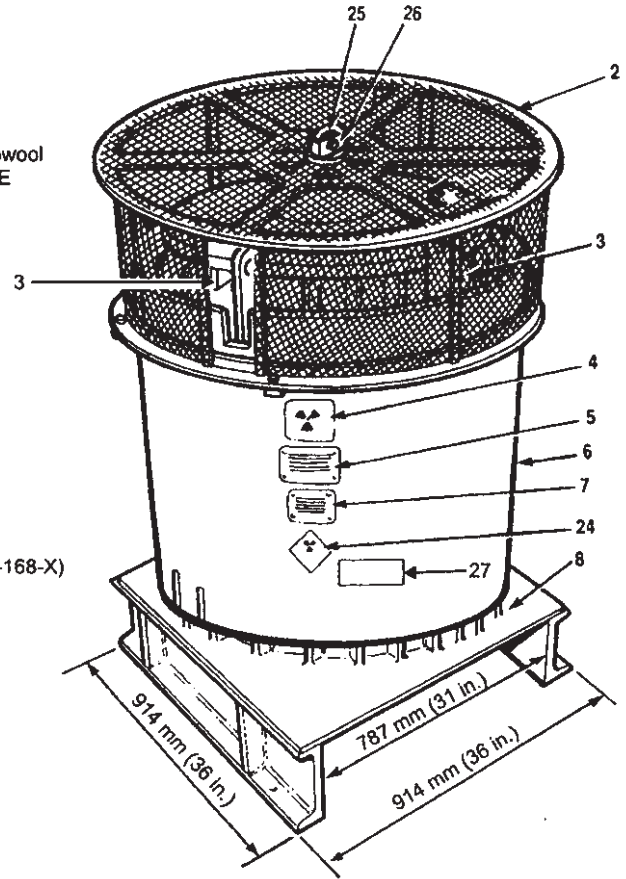

**Notes**

1. CNSC Certificate CDN/2081/B(U)-96
2. Meets IAEA Type B(U) Requirements
3. Steel encased lead shielding: 266 mm (10.5 in.)
4. Gross Weight: 5445 kg (12,000 lb.)
5. Plug Weight: 177 kg (390 lb.)
6. Projected Floor Loading: 2900 kg/m<sup>2</sup> (593 lb/ft<sup>2</sup>)
7. Radionuclides carried:
  1. Cobalt-60
  2. Antimony-124
  3. Cesium-137
8. Labels may be positioned as illustrated, or 45° to that shown

**MDS Nordion**

447 March Road, P.O. Box 13500  
 Kanata, Ontario, Canada, K2K 1X8  
 Tel: (613) 592-2790 · Fax: (613) 592-6937

**TITLE**

**F-168 and F-168-X Transport Package  
 (To IAEA 1996 Transport Regulations)**

REF. IN/SS 1812 F168X F116801-001/F116801-020	REVISED Nov 02	DCN A2119-D-08A
DATE Nov 2001	No. <b>F-168(-X) (1996)</b>	ISSUE <b>2</b>
DRAWN <i>[Signature]</i>	CHECKED <i>[Signature]</i>	APPROVED <i>[Signature]</i>
SHEET 1 OF 2		

THIS DRAWING IS THE PROPERTY OF MDS NORDION AND IS SUBMITTED FOR CONSIDERATION ON THE UNDERSTANDING THAT THERE SHALL BE NO EXPLOITATION OF ANY INFORMATION CONTAINED HEREIN EXCEPT WITH THE SPECIFIC WRITTEN AGREEMENT OF MDS NORDION.





U.S. Department  
of Transportation

East Building, PHH-23  
1200 New Jersey Avenue SE  
Washington, D.C. 20590

**Pipeline and  
Hazardous Materials  
Safety Administration**

**CERTIFICATE NUMBER:** USA/0617/B(U)-96, Revision 7

**ORIGINAL REGISTRANT(S):**

Luc Desgagne  
Senior Licensing Coordinator  
Nordion (Canada) Inc.  
447 March Road  
Ottawa, K2K 1X8  
Canada

Jackie Kavanagh  
Manager, Facility & Transportation Licensing  
Nordion (Canada) Inc.  
447 March Road  
Ottawa, K2K 1X8  
Canada

**REGISTERED USER(S):**

Mr. Carlos Martinez  
Program Engineer  
GE-Hitachi Nuclear Energy Americas, LLC  
6705 Vallecitos Rd  
Sunol, 94586  
USA

Gwen McCaffrey  
QA Coordinator  
Best Theratronics Ltd.  
Best Theratronics  
413 March Road  
Ottawa, K2K 0E4  
Canada

Mr. C. Joseph Harless  
Director, Radiation Safety  
Sterigenics  
10811 Withers Cove Park Drive  
Charlotte, 28278  
USA

Ms. Samantha Mason  
Best Theratronics Ltd.  
413 March Road  
Ottawa,  
CANADA

Mr. Juan G. Ayala  
Regulatory Compliance  
GE-Hitachi Nuclear Energy Americas, LLC  
6705 Vallecitos Road  
Sunol, CA 94586