



U.S. Department
of Transportation

Pipeline and
Hazardous Materials
Safety Administration

East Building, PHH-23
1200 New Jersey Ave, SE
Washington, D.C. 20590

IAEA CERTIFICATE OF COMPETENT AUTHORITY
SPECIAL FORM RADIOACTIVE MATERIALS

CERTIFICATE USA/0502/S-96, REVISION 13

This certifies that the sources described have been demonstrated to meet the regulatory requirements for special form radioactive material as prescribed in the regulations of the International Atomic Energy Agency¹ and the United States of America² for the transport of radioactive material.

1. Source Identification - QSA Global, Inc. Model Nos. X54 (Manufactured before January 1, 1998), X540 (Manufactured on or after February 17, 1981), and X540/1 (Manufactured on or after September 27, 2000).
2. Source Description - Tungsten inert gas or laser seal welded cylindrical single or double encapsulations. The outer encapsulation is made of titanium or stainless steel and the inner encapsulation, if used, is made of titanium, stainless steel, or aluminum. Approximate exterior dimensions are 5.15 mm (0.2 in.) maximum diameter and 15.15 mm (0.6 in.) in length (Model X54); and 5.16 mm (0.2 in.) in diameter and 7.65 mm (0.3 in.) in length (Models X540 and X540/1). Construction shall be in accordance with attached Amersham Drawing No. A10639, Issue C (Model X54) or QSA Global Inc. Drawing No. R87527, Rev. H (Models X540 and X540/1).

¹ "Regulations for the Safe Transport of Radioactive Material, 2012 Edition, No. SSR-6" published by the International Atomic Energy Agency (IAEA), Vienna, Austria.

² Title 49, Code of Federal Regulations, Parts 100-199, United States of America.

CERTIFICATE USA/0502/S-96, REVISION 13

3. Radioactive Contents - No more than 17.0 TBq (459.5 Ci) of Cobalt-60, in the form of a metal, in the Model X54. No more than either: 20.0 TBq (540.5 Ci) of Cobalt-60 in the form of metal; 17.0 TBq (459.5 Ci) of Iridium-192 in the form of metal; or 5.56 TBq (150.3 Ci) of Selenium-75 in the form of physically inert and stable metal-selenide compound, in the Models X540 and X540/1. Only the activity of Ir-192 in special form may be determined from a measurement of the rate of decay or a measurement of the radiation level at a prescribed distance from the source.
4. Management System Activities - Records of Management System activities required by Paragraph 306 of the IAEA regulations shall be maintained and made available to the authorized officials for at least three years after the last shipment authorized by this certificate. Consignors in the United States exporting shipments under this certificate shall satisfy the requirements of Subpart H of 10 CFR 71.
5. Expiration Date - This certificate expires on January 31, 2028. Previous editions which have not reached their expiration date may continue to be used.

This certificate is issued in accordance with paragraph(s) 804 of the IAEA Regulations and Section 173.476 of Title 49 of the Code of Federal Regulations, in response to the December 2, 2022 petition by QSA Global, Inc., Burlington, MA, and in consideration of other information on file in this Office.

Certified By:



William Schoonover
Associate Administrator for Hazardous
Materials Safety

January 13, 2023
(DATE)

Revision 13 - Issued to extend the expiration date.

DRG NO. **A10639**

Item	Description	Material	Drawing No.	No. off
1	BODY	STAIN.STL.	A10636	ITEM.1 1
2	PLUG	STAIN.STL.	A10638	1
3	ACTIVE MATERIAL			

FOR ENGRAVING DETAIL
SEE DRAWING A62615

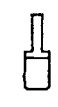
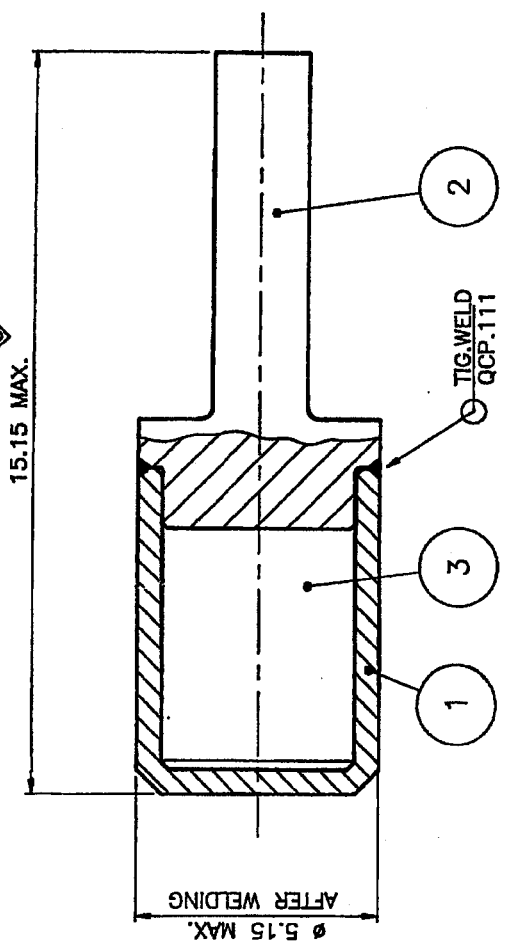

ACTUAL SIZE

TOLERANCES		MATERIAL		SCALE		C		MS1211		4.1.95		M.A.		DRAWN		CHECKED		APPROVED		QA APPROVED			
UNLESS OTHERWISE STATED		UNLESS OTHERWISE STATED		10:1		C		MS1211		4.1.95		M.A.		DRAWN		CHECKED		APPROVED		QA APPROVED			
SURFACE TEXTURE		FINISH		GENERAL NOTES		ISSUE		MOD No.		DATE		DATE		DATE		DATE		DATE		DATE			
UNLESS OTHERWISE STATED		REMOVE ALL BURRS		<p>THIRD ANGLE PROJECTION</p> <p>MODIFICATIONS INDICATED BY ISSUE IN THIS DRAWING CONFORMS TO BS308.</p> <p>ALL DIMENSIONS IN MILLIMETRES UNLESS OTHERWISE STATED.</p> <p>DO NOT SCALE</p> <p>APPROVAL</p> <p>THIS DRAWING IS NOT TO BE USED FOR ANY PURPOSE UNLESS SIGNED AS APPROVED</p>		<p>THIS DOCUMENT INCLUDING THE COPYRIGHT THEREIN IS THE EXCLUSIVE PROPERTY OF AMERSHAM INTERNATIONAL PLC. AMERSHAM U.K. IT MAY ONLY BE USED FOR THE PURPOSE FOR WHICH IT WAS ISSUED. IT MAY NOT BE REPRODUCED IN ANY WAY, NOR TRANSMITTED TO ANY THIRD PARTY WITHOUT THE EXPRESS PERMISSION OF AMERSHAM INTERNATIONAL PLC.</p> <p>Amersham The Health Science Group</p>		<p>SCALE</p> <p>10:1</p>		<p>ISSUE</p> <p>MOD No.</p>		<p>DATE</p>		<p>M.A.</p>		<p>DRAWN</p>		<p>CHECKED</p>		<p>APPROVED</p>		<p>QA APPROVED</p>	
TITLE		ASSEMBLY OF CAPSULE X54		USED ON		SHT. SIZE		A3		DRG NO.		A10639		SHT 1 OF		SHTS 1							

X540,540/1 LID SHANK

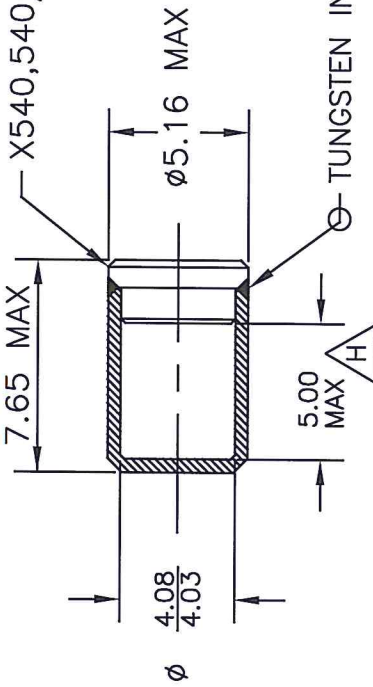

MODEL	MATERIAL
X540	316L STAINLESS STEEL
X540/1	TITANIUM

NOTES:

- INTERNAL VOID TO BE 0.010 mL OR GREATER.
- MATERIAL: SEE TABLE
- INNER CAVITY DIMENSIONS MAY VARY. METALLIC SPACERS, SPRINGS AND GUARDS WHICH SECURE AND/OR LOCATE THE RADIOACTIVE MATERIAL OR INNER SOURCE CAPSULE WITHIN THE CAPSULE MAY BE USED.
- MINIMUM WALL THICKNESS TO BE 0.22.
- DIMENSIONS ARE IN MILLIMETERS

NOTES:

- MATERIAL: SEE TABLE

APPROVALS	DATE	 40 NORTH AVE, BURLINGTON, MA 01803	DESCRIPTIVE DRAWING
<i>R. Smith</i>	04 DEC 17		
	Dec 17	TITLE	X540 CAPSULE SERIES
UNLESS OTHERWISE SPECIFIED DIMENSIONS IN INCHES TOLERANCES: FRACTIONS $\pm 1/8$ XX ± 0.12 X.XX ± 0.06 X.XXX ± 0.020		SIZE	DWG. NO. R87527
		A	SCALE: NONE
			SHEET 1 OF 1
			REV H

ERF # 3726



U.S. Department of
Transportation

**Pipeline and
Hazardous Materials
Safety Administration**

East Building, PHH-23
1200 New Jersey Ave, SE
Washington, D.C. 20590

CERTIFICATE NUMBER: USA/0502/S-96

ORIGINAL REGISTRANT(S) :

QSA Global, Inc.
40 North Avenue
Burlington, MA, 01803
USA

Industrial Nuclear Company, Inc.
14320 Wicks Blvd.
San Leandro, CA, 94577
USA