



U.S. Department
of Transportation

1200 New Jersey Avenue, S.E.
Washington, D.C. 20590

**Pipeline and
Hazardous Materials
Safety Administration**

**IAEA CERTIFICATE OF COMPETENT AUTHORITY
SPECIAL FORM RADIOACTIVE MATERIALS
CERTIFICATE USA/0356/S-96, REVISION 13**

This certifies that the sources described have been demonstrated to meet the regulatory requirements for special form radioactive material as prescribed in the regulations of the International Atomic Energy Agency¹ and the United States of America² for the transport of radioactive material.

1. Source Identification - Eckert & Ziegler Isotope Products Model HEG-XXX Series (A3000, A3000-1, A3015, A3015-1, A3023, A3024-1, A3024-2, A3024-3, and A3024-4), where XXX represents the radionuclide mass number.
2. Source Description - Cylindrical double encapsulations made of Type 304 or 304L stainless steel and fusion welded. Approximate external dimensions are 6.4 mm (0.25 in.) in diameter and 15.9 mm (0.625 in.) in length (Models A3000 and A3000-1); 6.0 mm (0.236 in.) in diameter and 8.0 mm (0.315 in.) in length (Models A3015 and A3015-1); 6.0 mm (0.236 in.) in diameter and 12.0 mm (0.473 in.) in length with one end having an internal 3-48 thread (Model A3023); and 6.0 mm (0.236 in.) in diameter and 10.0 mm (0.394 in.) in length (Models A3024-1, A3024-2, A3024-3, and A3024-4). Construction shall be in accordance with attached Isotope Products Laboratories Drawing Nos. 3000 or 3015 (Sheet 3 or 4 of 8); or Eckert & Ziegler Isotope Products Drawing Nos. 3023, 3000 or 3024 (Sheet 4 or 5 of 8).
3. Radioactive Contents - The sources described by this certificate are authorized to contain any one of the following radionuclides in the chemical form identified and limited to the activity shown.

<u>Radionuclide</u>	<u>Form</u>	<u>Activity GBq (Ci)</u>	
Na-22	NaCl in gold or ceramic	3.7	(0.10)
Co-57	CoCl ₂ or CoO in ceramic or Co metal plated on Ni foil	11.1	(0.30)
Co-58	CoCl ₂ or CoO in ceramic	11.1	(0.30)
Co-60	CoCl ₂ or CoO in ceramic or 1 mm x 1mm Ni clad Co	22.2	(0.60)
Ge-68	GeO ₂ in silver	1.9	(0.05)
Ba-133	BaSO ₄ in ceramic	3.7	(0.10)
Cs-137	CsCl in gold or Cs in ceramic	22.2	(0.60)
Eu-152	Oxide in gold or ceramic	0.74	(0.020)
Ra-226	RaSO ₄ in gold or ceramic	1.9	(0.05)
Cf-252	Oxide in metal or ceramic	0.037	(0.001)
Actinides*	Oxides in gold or ceramic	1.9	(0.05)

*(Isotopes of Ac, Th, Pa, Np, U, Pu, Am, and Cm only)

4. Quality Assurance - Records of Quality Assurance activities required by paragraph 310 of the IAEA regulations¹ shall be maintained and made available to the authorized officials for at least three years after the last shipment authorized by this certificate. Consignors in the United States exporting shipments under this certificate shall satisfy the requirements of Subpart H of 10 CFR 71.

¹ "Regulations for the Safe Transport of Radioactive Material, 1996 Edition (Revised), No. TS-R-1 (ST-1, Revised)," published by the International Atomic Energy Agency (IAEA), Vienna, Austria.

² Title 49, Code of Federal Regulations, Parts 100 - 199, United States of America.

CERTIFICATE USA/0356/S-96, REVISION 13

5. Expiration Date - This certificate expires on October 31, 2019.

This certificate is issued in accordance with paragraph 804 of the IAEA Regulations and Section 173.476 of Title 49 of the Code of Federal Regulations, in response to the October 10, 2014 petition by Eckert & Ziegler Isotope Products, Valencia, CA, and in consideration of other information on file in this Office.

Certified by:

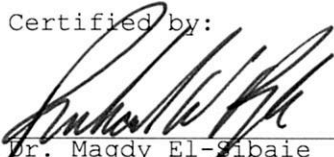

Dr. Magdy El-Sibaie
Associate Administrator for
Hazardous Materials Safety

OCT 21 2014

(DATE)

Revision 13 - Issued to extend the expiration date and update Drawing No. 3023.

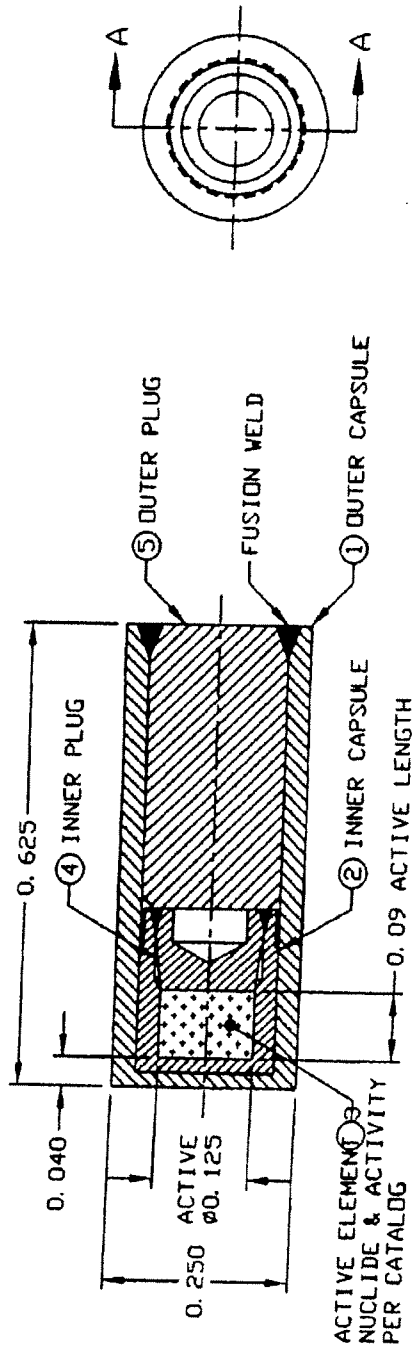

SECTION A-A

SECTION A-A

3. IDENTIFY PART NUMBER
 2. ALL CAPSULES AND PLUGS ARE MADE FROM 304 OR 304L STAINLESS STEEL AND THE ACTIVE ELEMENT IS CERAMIC
 1. ASSEMBLE COMPLETE PER ENGINEERING DRAWING AND FUSION WELD AS REQUIRED
- NOTES: UNLESS OTHERWISE SPECIFIED

<p>Isotope Products Laboratories An Eckert & Ziegler Company VALENCIA, CALIFORNIA 91355</p>		<p>P/N A3000 ASSEMBLY, MODEL 225 POINT SOURCE</p>	
<p>UNLESS OTHERWISE SPECIFIED DIMENSIONS ARE IN INCHES</p>		<p>DESIGN EZ/DI</p>	<p>DRAWING TITLE MODEL 225 POINT SOURCE</p>
<p>FRACTION ±1/64</p>	<p>TOLERANCES ON DECIMAL ±.1 .01 .002</p>	<p>SCALE NONE</p>	<p>SERIES TITLE INDUSTRIAL SOURCES, HIGH INTENSITY GAMMA AND NEUTRON</p>
<p>THIRD ANGLE PROJECTION</p>		<p>SIZE A</p>	<p>CAGE CODE 32993</p>
		<p>REVISION K</p>	<p>DRAWING NUMBER 3000</p>
			<p>SHEET 3 OF 10</p>

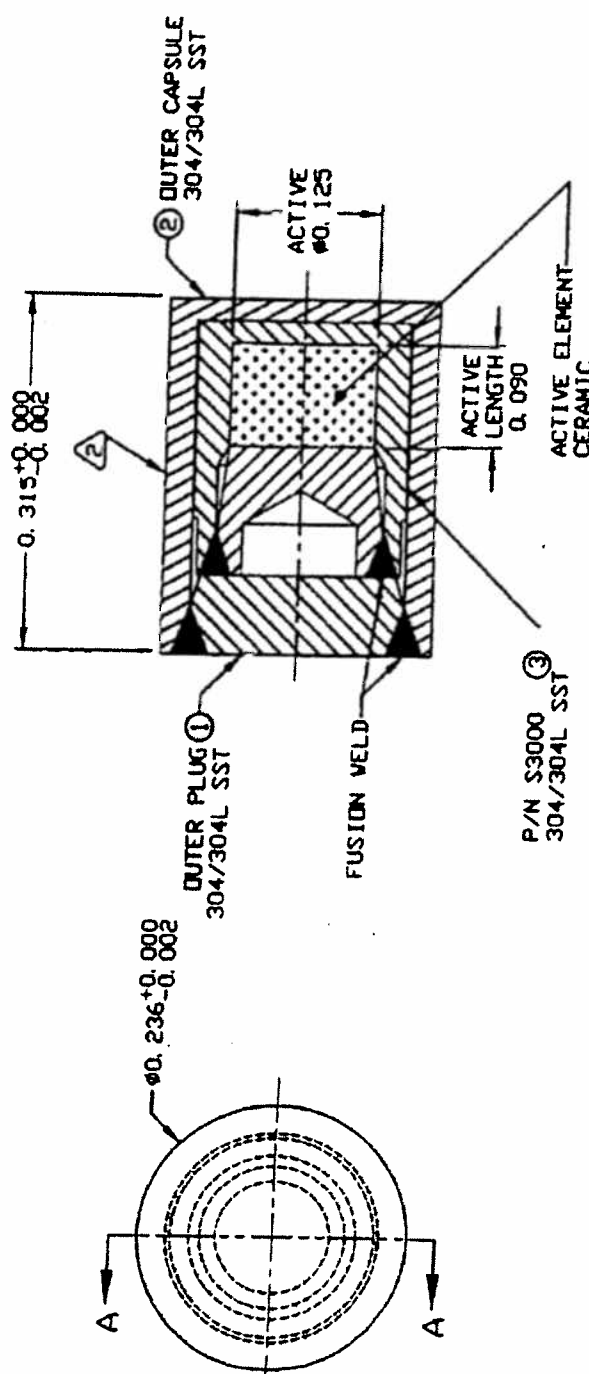

SECTION A-A

- 3. IDENTIFY PART NUMBER
- ENGRAVE CHARACTERS 0.060 HIGH x 0.003 DEEP MAXIMUM AS SHOWN
- IPL NUCLIDE ACTIVITY SERIAL NUMBER
- 1. ASSEMBLE COMPLETE PER ENGINEERING DRAWING AND PER PROCEDURE

NOTES: UNLESS OTHERWISE SPECIFIED

Isotope Products Laboratories
 An Eckert & Ziegler Company
 VALENCIA, CALIFORNIA 91355

P/N A3015 ASSEMBLY

UNLESS OTHERWISE SPECIFIED DIMENSIONS ARE IN INCHES		DESIGN	DRAWING TITLE	
FRAC-TION	TOLERANCES ON DECIMAL	EZ/DI	SPECIAL 225 CAPSULE, GAMMA POINT SOURCE	
1/64	± .1	SCALE	SERIES TITLE	
		NONE	INDUSTRIAL SOURCES, HIGH INTENSITY	
		SIZE	CAGE CODE	REVISION
		A	32993	G
THIRD ANGLE PROJECTION		DRAWING NUMBER		SHEET
		3015		3 OF 8

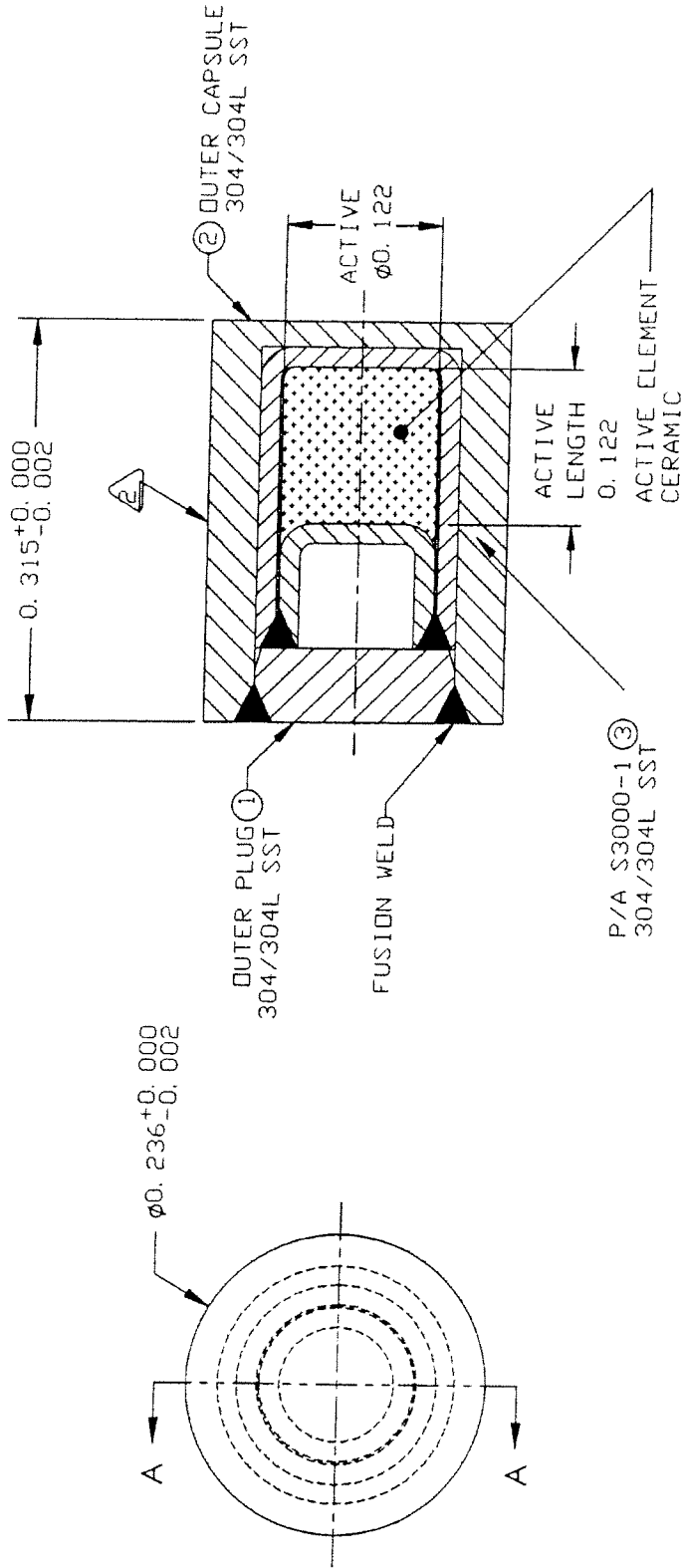

3. IDENTIFY PART NUMBER
 ENGRAVE CHARACTERS 0.060 HIGH x 0.003 DEEP MAXIMUM
 AS SHOWN:
 IPL NUCLIDE ACTIVITY SERIAL NUMBER
 1. ASSEMBLE COMPLETE PER ENGINEERING DRAWING
 AND PER PROCEDURE.

NOTES: UNLESS OTHERWISE SPECIFIED

 Isotope Products
 Laboratories
 An Eckert & Ziegler Company
 VALENCIA, CALIFORNIA 91355

A3015-1 ASSEMBLY

UNLESS OTHERWISE SPECIFIED DIMENSIONS ARE IN INCHES		DESIGN EZ/DI	DRAWING TITLE SPECIAL 225 CAPSULE, GAMMA POINT SOURCE	
FRAC- TION ±1/64	TOLERANCES ON DECIMAL X ±.1	SCALE NONE	SERIES TITLE INDUSTRIAL SOURCES, HIGH INTENSITY GAMMA AND NEUTRON	
THIRD ANGLE PROJECTION 		SIZE A	CAGE CODE 32993	REVISION DRAWING NUMBER G 3015
			SHEET 4 OF 8	

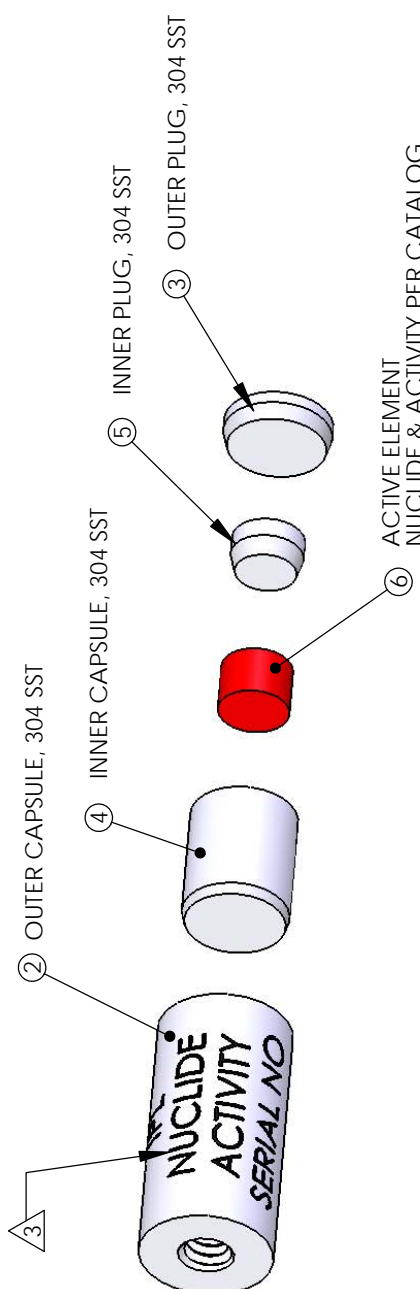
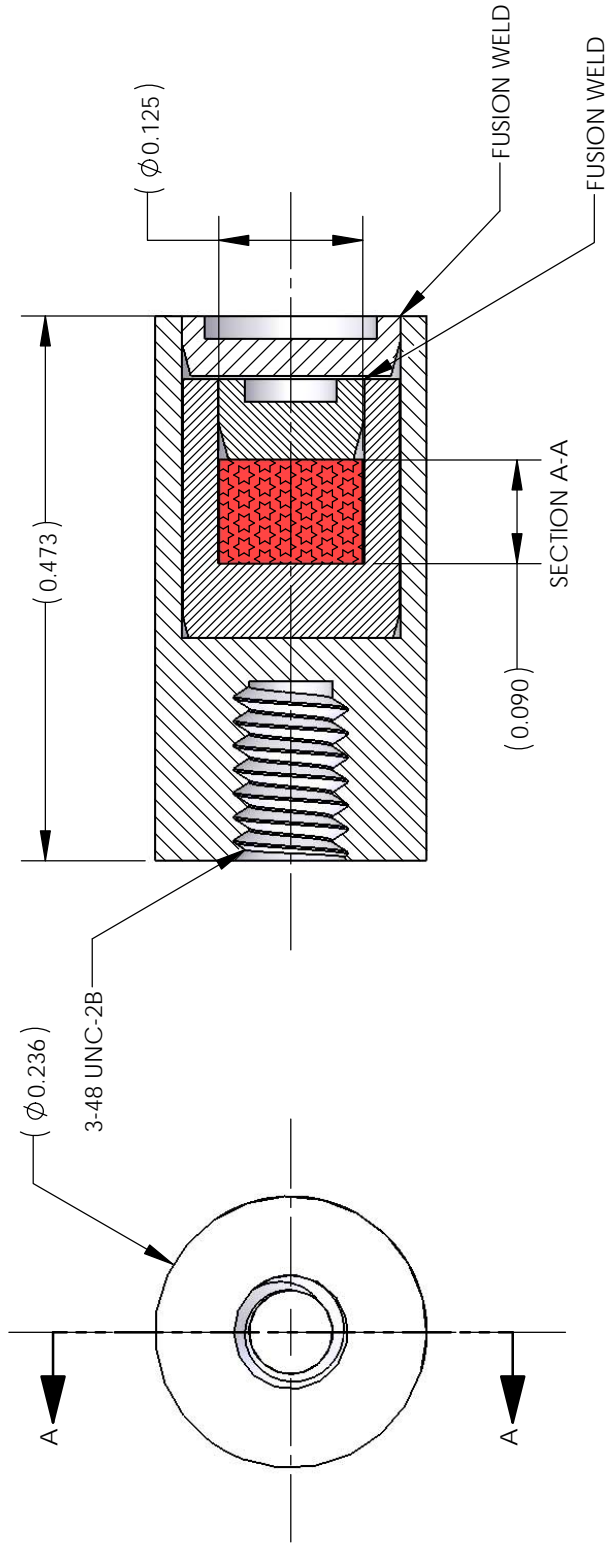

1. ENGRAVE CHARACTERS 0.060 HIGH X 0.003 DEEP MAX AS SHOWN (BLACK FILL)
 PL, NUCLIDE, ACTIVITY, SERIAL NO.
 2. PACKAGE AND IDENTIFY PART NUMBER THEREON
 1. ASSEMBLE PER ENGINEERING DRAWING
- NOTES: UNLESS OTHERWISE SPECIFIED

P/N A3023 GAMMA METRICS ASSEMBLY

<p>Eckert & Ziegler Isotope Products</p> <p>VALENCIA, CALIFORNIA 91355</p>	CAGE CODE 32993 DRAWING SIZE LETTER TITLE UNLESS OTHERWISE SPECIFIED DIMENSIONS ARE IN INCH SIZES. METRIC UNITS (mm) ARE IN MILLIMETERS.		DRAWN JMD/RLT ME/CHECKER SC ENGINEER EZ SCALE 6:1	TITLE GAMMA METRICS SERIES TITLE HIGH INTENSITY GAMMA AND NEUTRON SOURCES
	TOLERANCES (UNLESS OTHERWISE SPECIFIED) X.XXX ± .002 INCH ANGULAR TOLERANCE OF 0° ± 30' X.XX ± .005 INCH FRACTIONAL DIMENSIONS ± 1/32" X.X ± .03 INCH REFERENCE DIMENSIONS () N/A X. ± .1 INCH SURFACE ROUGHNESS μ INCH MAX	DRAWING NO. 3023 REV B SHEET 3 OF 7		

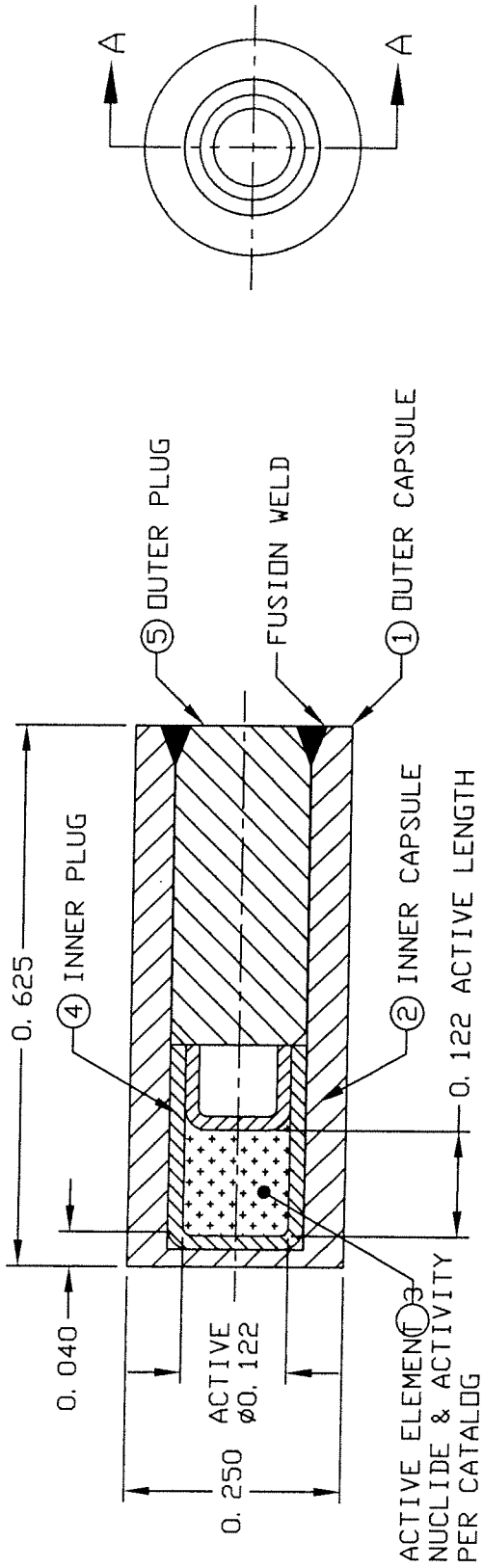

SECTION A-A

SECTION A-A

3. IDENTIFY PART NUMBER
 2. ALL CAPSULES AND PLUGS ARE MADE FROM 304 OR 304L STAINLESS STEEL AND THE ACTIVE ELEMENT IS CERAMIC
 1. ASSEMBLE COMPLETE PER ENGINEERING DRAWING AND FUSION WELD AS REQUIRED
- NOTES: UNLESS OTHERWISE SPECIFIED

Eckert & Ziegler

Isotope Products

Valencia, California 91355

THIS DRAWING IS THE PROPERTY OF ISOTOPE PRODUCTS LABORATORIES AND MAY NOT BE USED, REPRODUCED, PUBLISHED OR DISCLOSED TO OTHERS WITHOUT EXPRESS AUTHORIZATION BY ISOTOPE PRODUCTS LABORATORIES.

P/N A3000-1 ASSEMBLY, MODEL 225 POINT SOURCE

DESIGN	EZ/DI	DRAWING TITLE	MODEL 225 POINT SOURCE
SCALE	NONE	SERIES TITLE	INDUSTRIAL SOURCES, HIGH INTENSITY GAMMA AND NEUTRON
SIZE	A	CAGE CODE	32993
THIRD ANGLE PROJECTION		REVISION	K
		DRAWING NUMBER	3000
		SHEET	4 OF 10

UNLESS OTHERWISE SPECIFIED DIMENSIONS ARE IN INCHES	FRAC-TION	TOLERANCES ON	ANGLE
	±1/64	DECIMAL	±.5°
		XX	.01
		XXX	.002

A(CENTER OF ACTIVITY)	A3024-1	A3024-3
B(ACTIVE DIAMETER)	0.085[2.16]	0.085[2.16]
C(ACTIVE LENGTH)	0.125[3.18]	0.125[3.18]
ENGRAVING	0.090[2.29]	0.090[2.29]
	STANDARD	CUSTOMER SPECIFIC

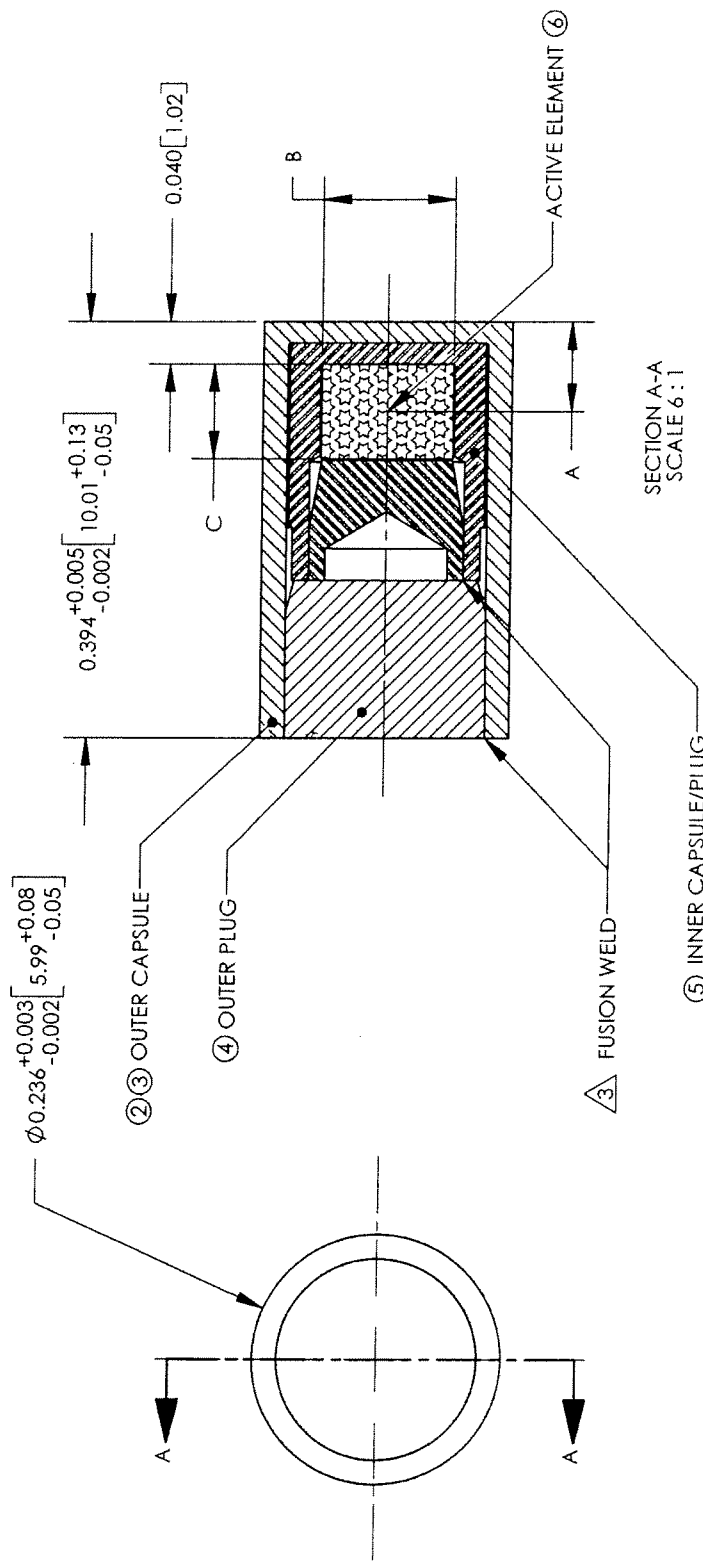

SECTION A-A
SCALE 6:1

▲ FUSION WELD AS REQUIRED 0.015 MINIMUM WELD DEPTH
 2. PACKAGE AND IDENTIFY PART NUMBER THEREON
 1. ASSEMBLE PER ENGINEERING DRAWING.
 NOTES: UNLESS OTHERWISE SPECIFIED

A3024-1/ A3024-3 ASSEMBLY

Eckert & Ziegler Isotope Products VALENCIA, CALIFORNIA 91355	UNLESS OTHERWISE SPECIFIED DIMENSIONS ARE IN INCH-SIZES; METRIC UNITS (mm) ARE IN MILLIMETERS.		DRAWN RLT	TITLE HEG SOURCE, 1cm LENGTH	REV F	SHEET 4 OF 8
	TOLERANCES (UNLESS OTHERWISE SPECIFIED) X.XXX ± .002 INCH ANGULAR TOLERANCE OF 0°±30' X.XX ± .005 INCH FRACTIONAL DIMENSIONS ± 1/32" X.X ± .03 INCH REFERENCE DIMENSIONS (I) N/A X. ± .1 INCH SURFACE ROUGHNESS (INCH MAX) ALL DIMENSIONS ARE FINISHED DIMENSIONS	ME/CHECKER LF	ENGINEER RMD	ME/CHECKER LF	SERIES TITLE INDUSTRIAL SOURCES, HIGH INTENSITY GAMMA AND NEUTRON	CAGE CODE 32993
THIRD ANGLE PROJECTION	SCALE NONE	SIZE A	SCALE NONE	CAGE CODE 32993	DRAWING NO. 3024	SHEET 4 OF 8

THIS DRAWING IS THE PROPERTY OF ECKERT&ZIEGLER ISOTOPE PRODUCTS AND MAY NOT BE USED, REPRODUCED, PUBLISHED OR ENCLOSED TO OTHERS WITHOUT EXPRESS AUTHORIZATION BY ECKERT&ZIEGLER ISOTOPE PRODUCTS.

A(CENTER OF ACTIVITY)	A3024-2	A3024-4
B(ACTIVE DIAMETER)	0.099[2.51]	0.099[2.51]
C(ACTIVE LENGTH)	0.118[3.00]	0.118[3.00]
ENGRAVING	STANDARD	CUSTOMER SPECIFIC

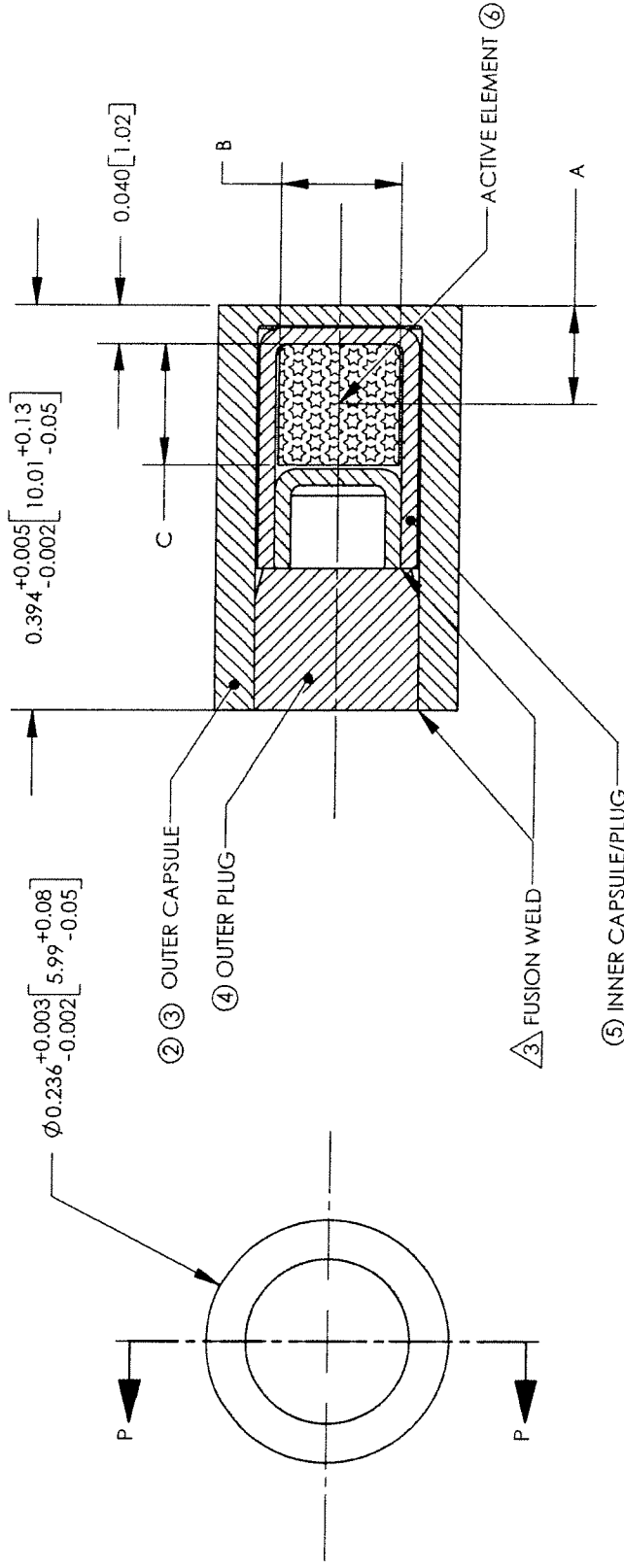

- FUSION WELD AS REQUIRED 0.015 MINIMUM WELD DEPTH
 - PACKAGE AND IDENTIFY PART NUMBER THEREON
 - ASSEMBLE PER ENGINEERING DRAWING.
- NOTES: UNLESS OTHERWISE SPECIFIED

Eckert & Ziegler
Isotope Products
VALENCIA, CALIFORNIA 91355

THIS DRAWING IS THE PROPERTY OF ECKERT & ZIEGLER ISOTOPE PRODUCTS AND MAY NOT BE USED, REPRODUCED, PUBLISHED OR DISCLOSED TO OTHERS WITHOUT EXPRESS AUTHORIZATION BY ECKERT & ZIEGLER ISOTOPE PRODUCTS.

UNLESS OTHERWISE SPECIFIED DIMENSIONS ARE IN INCH-SIZES. METRIC UNITS [mm] ARE IN MILLIMETERS.	
TOLERANCES	(UNLESS OTHERWISE SPECIFIED)
X.XXX ± .002	INCH ANGULAR TOLERANCE OF 0°±30'
X.XX ± .005	INCH FRACTIONAL DIMENSIONS ± 1/32"
X.X ± .03	INCH REFERENCE DIMENSIONS (I) N/A
X ± .1	INCH SURFACE ROUGHNESS 1 INCH MAX
ALL DIMENSIONS ARE FINISHED DIMENSIONS	
THIRD ANGLE PROJECTION	

DRAWN	RLT
ME/CHECKER	LF
ENGINEER	RMD
SCALE	NONE
SIZE	A

TITLE	HEG SOURCE, 1cm LENGTH
SERIES TITLE	INDUSTRIAL SOURCES, HIGH INTENSITY GAMMA AND NEUTRON
CAGE CODE	32993
DRAWING NO.	3024
REV	F
SHEET	5 OF 8

A3024-2/A3024-4 ASSEMBLY



U.S. Department
of Transportation

East Building, PHH-23
1200 New Jersey Avenue SE
Washington, D.C. 20590

**Pipeline and
Hazardous Materials
Safety Administration**

CERTIFICATE NUMBER: USA/0356/S-96, Revision 13

ORIGINAL REGISTRANT(S):

Ms. Frida Tan
Regulatory Affairs Manager
Eckert & Ziegler Isotope Products
24937 Avenue Tibbitts
Valencia, 91355
USA

REGISTERED USER(S):

Ms. Mary Shepherd
Vice President
J.L. Shepherd & Associates
1010 Arroyo Ave.
San Fernando, 91340-1822
USA

Ms. Elizabeth Foltz
Manager, Global Radiation and Explosives Safety
Halliburton
3000 North Sam Houston Parkway, East
Houston, 77032
USA

Sean Hunt
Stuart Hunt & Associates Ltd
20 Rayborn Crescent St.
Alberta, Canada T8N 5C1
Canada

Norman P. Lanier
Corporate Radiation Safety Officer
Tru-Tec Services, Inc.
11005 West Fairmont Parkway
La Porte, 77571
USA

Mr. Henry Barnes
Corporation Radiation Safety Officer
Troxler Electronic Laboratories
P.O. Box 12057
3008 Cornwallis Road
Research Triangle Park, 27709
USA

Mr. Darrell Liles
U.S. Geologic Survey
Department of the Interior
P.O. Box 25046 (MS-974)
Denver, CO 80225-0046

Cameron Musgrave
Senior Radiation Safety Technician, Quality Management Representative
Stuart Hunt & Associates Ltd
5949 Ambler Drive
Mississauga, Ontario L4W 2K2
Canada

Mr. Steve Woods
Global Radiation and Explosives Safety
Halliburton
1015 W Bois D Arc Ave
Duncan, OK 73536

Mr. Neil Walters
Global Radiation and Explosives Safety
Halliburton
3300 N. Sam Houston Parkway East
Houston, TX 77032

Ms. Jill Mead
Global RSO
Halliburton
3000 North Sam Houston Parkway, East
Houston, 77032
USA